

FG/FCG-01-\*\*-\*\*-11/1190

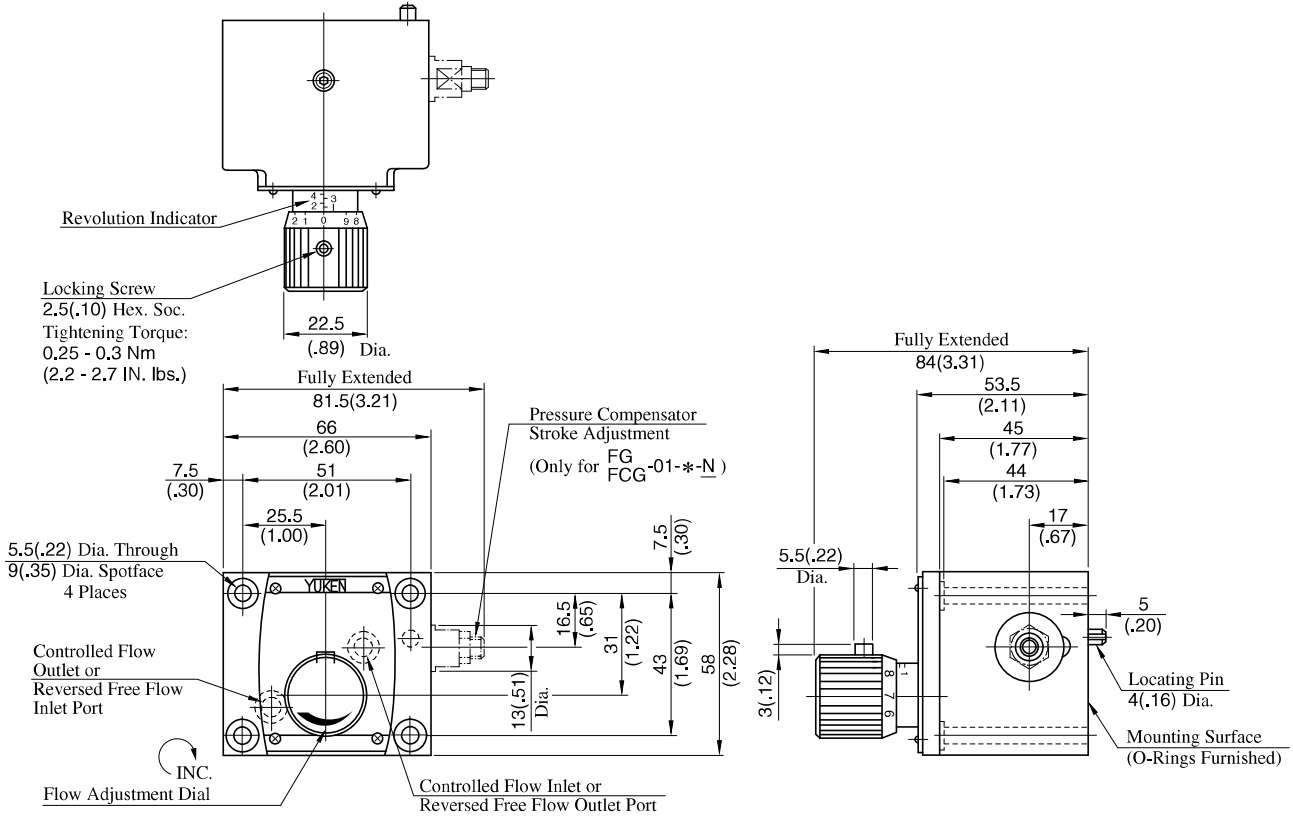

DIMENSIONS IN  
MILLIMETRES (INCHES)

FG/FCG-02-30-\*\*-30/3090  
FG/FCG-03-125-\*\*-30/3090

Mounting surface:  
F\*G-02: ISO 6263-AB-06-4-B  
F\*G-03: ISO 6263-AK-07-2-A

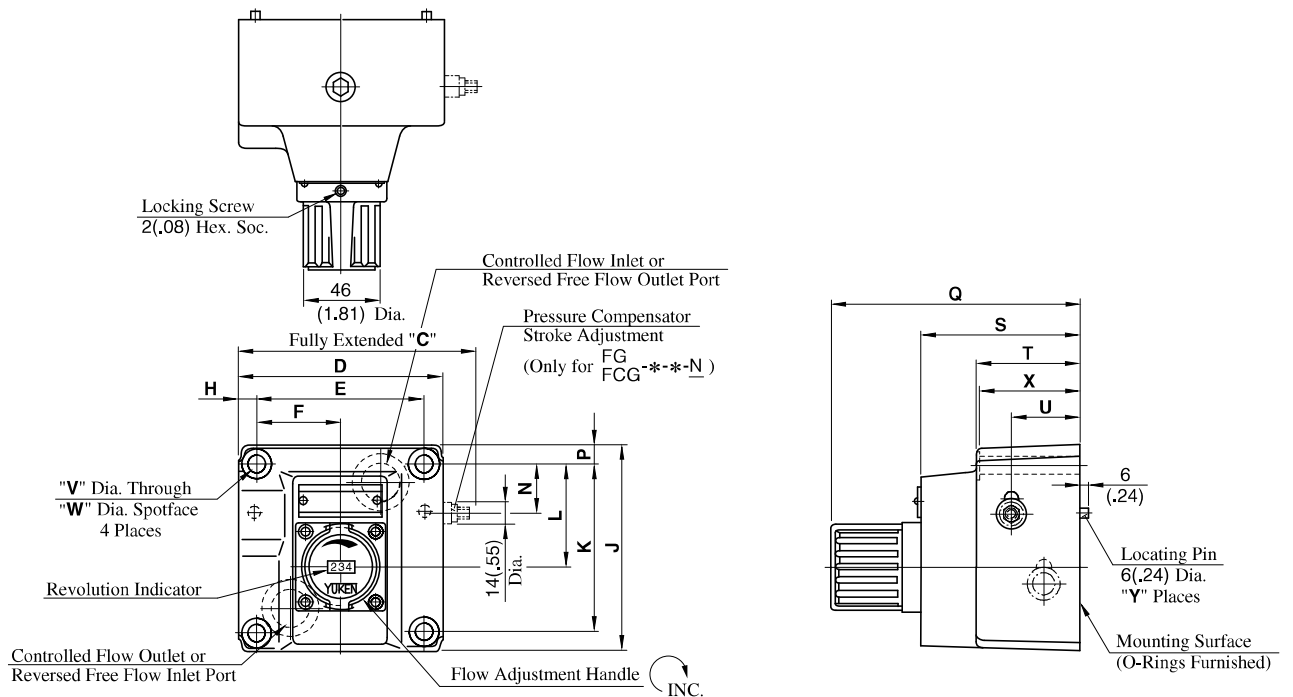

Model No.	Dimensions mm (Inches)																	Y
	C	D	E	F	H	J	K	L	N	P	Q	S	T	U	V	W	X	
FG FCG <sup>02</sup>	116 (4.57)	96 (3.78)	76.2 (3.00)	38.1 (1.50)	9.9 (.39)	104.5 (4.11)	82.6 (3.25)	44.3 (1.74)	24 (.94)	9.9 (.39)	123 (4.84)	69 (2.72)	40 (1.57)	23 (.91)	8.8 (.35)	14 (.55)	39 (1.54)	1
FG FCG <sup>03</sup>	145 (5.71)	125 (4.92)	101.6 (4.00)	50.8 (2.00)	11.7 (.46)	125 (4.92)	101.6 (4.00)	61.8 (2.43)	29.8 (1.17)	11.7 (.46)	152 (5.98)	98 (3.86)	64 (2.52)	41 (1.61)	11 (.43)	17.5 (.69)	63 (2.48)	2

D  
Flow Control Valves  
Flow Control and Check Valves