

Flange Mtg. Two Bolts:A3HG37-FR14K-E1C/E2C/U1C/U2C/J1C

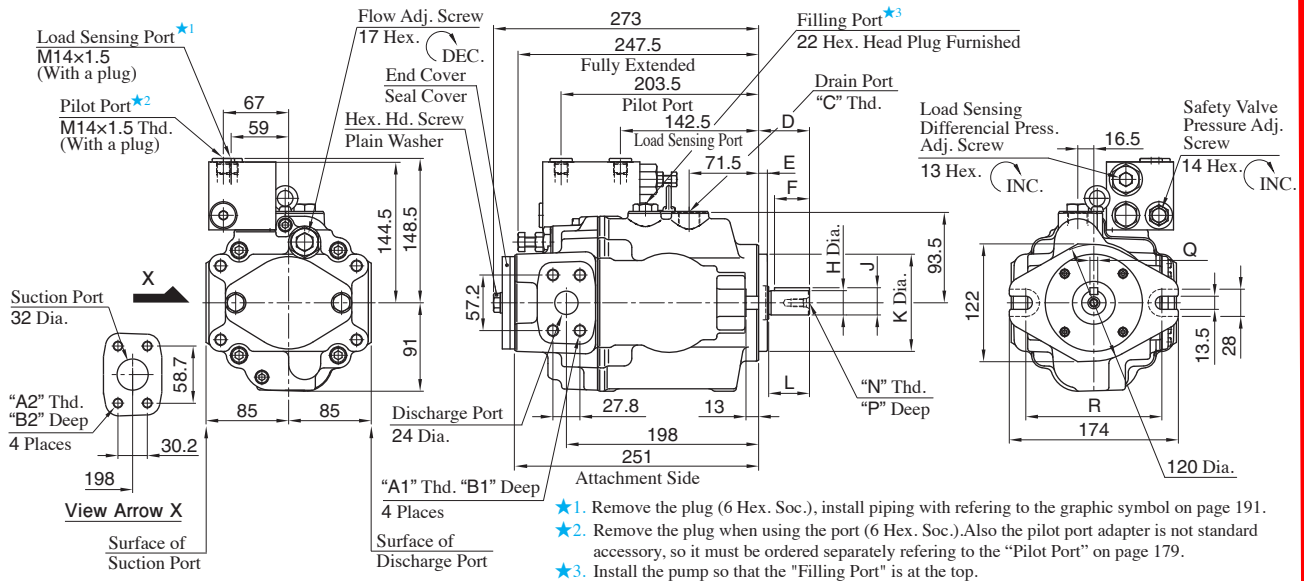

Model Numbers	A1	A2	B1	B2	C	D	E	F	H	J	K	L	N	P	Q	R	Mounting Flange	Connecting Port	Pipe Flange Threads
A3HG37-FR14K-E1C/E2C	M12	M10	22	18	M22X1.5	52	9	36	25 ^{+0.009} _{-0.004}	28 ^{+0.009} _{-0.294}	100 ⁰ _{0.054}	42	M8	19	8 ⁰ _{-0.036}	140	Conforms to ISO 3019-2	Metric	Metric
A3HG37-FR14K-U1C	7/16-14 UNC		20		G 1/2	46	9.7	32	25.4 ⁰ _{-0.05}	28.18 ⁰ _{0.18}	101.6 ⁰ _{0.05}	38	1/4-20 UNC	16	6.35 ^{+0.03} ₀	146	Conforms to ISO 3019-1	Unified	Unified
A3HG37-FR14K-U2C	M12	M10	22	18	G 1/2	46	9.7	32	25.4 ⁰ _{-0.05}	28.18 ⁰ _{0.18}	101.6 ⁰ _{0.05}	38	1/4-20 UNC	16	6.35 ^{+0.03} ₀	146	Conforms to ISO 3019-1	BSP	Metric
A3HG37-FR14K-J1C	M12	M10	22	18	G 1/2	46	9.7	32	25.4 ⁰ _{-0.05}	28.18 ⁰ _{0.18}	101.6 ⁰ _{0.05}	38	1/4-20 UNC	16	6.35 ^{+0.03} ₀	146	Conforms to ISO 3019-1	Rc	Metric

Flange Mtg. Four Bolts:A3HG37-FR14K-E1D/E2D/U1D/U2D/J1D

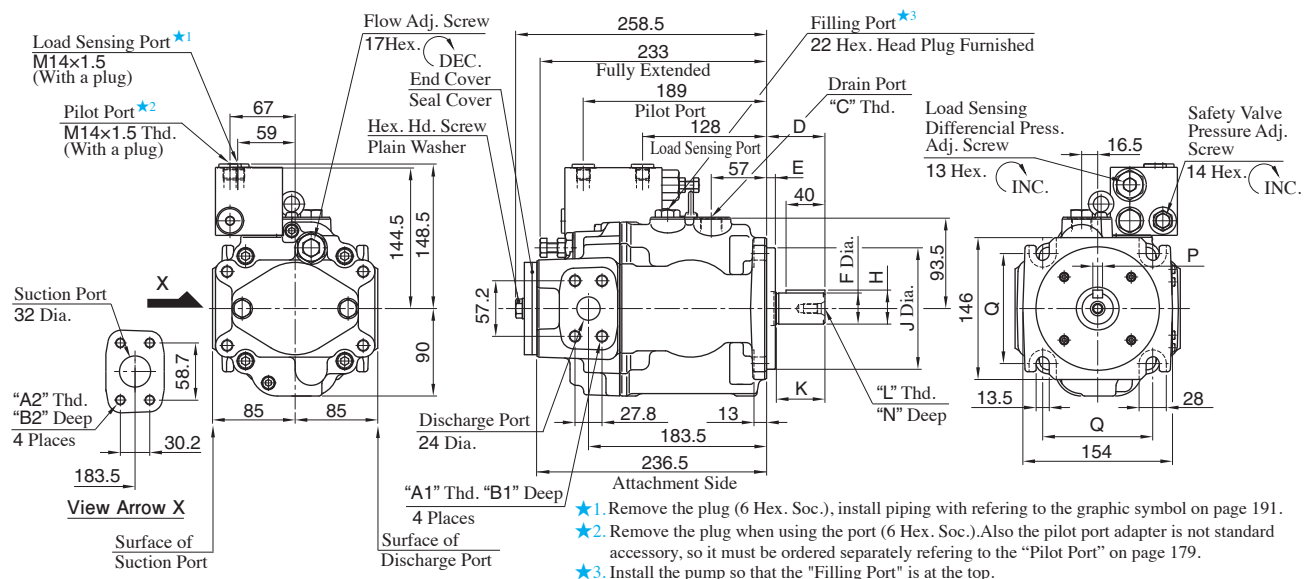

Model Numbers	A1	A2	B1	B2	C	D	E	F	H	J	K	L	N	P	Q	Mounting Flange	Connecting Port	Pipe Flange Threads
A3HG37-FR14K-E1D/E2D	M12	M10	22	18	M22X1.5	60	9	32 ^{+0.018} _{+0.002}	35 ^{+0.018} _{-0.288}	125 ⁰ _{0.063}	50	M10	22	10 ⁰ _{-0.036}	113.2	Conforms to ISO 3019-2	Metric	Metric
A3HG37-FR14K-U1D	7/16-14 UNC		20		G 1/2	56	12.7	31.75 ⁰ _{-0.05}	35.32 ⁰ _{-0.18}	127 ⁰ _{-0.05}	48	5/16-18 UNC	19	7.94 ^{+0.03} ₀	114.5	Conforms to ISO 3019-1	Unified	Unified
A3HG37-FR14K-U2D	M12	M10	22	18	G 1/2	56	12.7	31.75 ⁰ _{-0.05}	35.32 ⁰ _{-0.18}	127 ⁰ _{-0.05}	48	5/16-18 UNC	19	7.94 ^{+0.03} ₀	114.5	Conforms to ISO 3019-1	BSP	Metric
A3HG37-FR14K-J1D	M12	M10	22	18	G 1/2	56	12.7	31.75 ⁰ _{-0.05}	35.32 ⁰ _{-0.18}	127 ⁰ _{-0.05}	48	5/16-18 UNC	19	7.94 ^{+0.03} ₀	114.5	Conforms to ISO 3019-1	Rc	Metric

Load Sensing Port/Pilot Port

Load Sensing Port is common to that of Pilot Port(except the height dimension from the center of the pump). Refer to page 179 for the dimensions of Pilot Port.

Drain Port

Drain Port is common to that of pressure compensator model.Refer to page 168 or 169 for the dimensions of Drain Port.

Foot Mtg.:A3HG37-LR14K-E1C/E2C/U1C/U2C/J1C, A3HG37-LR14K-E1D/E2D/U1D/U2D/J1D

Mounting bracket is common to that of pressure compensator model (except max height dimension). Refer to page 168 and 169 for the dimensions of mounting bracket.