

## 40Ω Series

# Proportional Electro-Hydraulic Flow Control (and Check) Valves

Since the preselected flow rate continuously varies in proportion to the current input to the valve, the system flow rate can be remote-controlled as desired by regulating the amplifier current output. Further, since pressure and temperature compensation functions are provided, the preselected flow rate is not affected by pressure (load) or temperature (fluid viscosity).

This valve is ideal for use where actuator startup, stop, and speed changes are to be implemented without producing a shock. Note that this valve is used in conjunction with the applicable power amplifier.



### Specifications

Model No.	EFG EFCG -02-10 EFCG -02-30	EFG EFCG -03-60 EFCG -03-125	EFG EFCG -06-250	EFG EFCG -10-500
Max. Operating Pres. MPa (PSI)	20.6 (3000)	20.6 (3000)	20.6 (3000)	20.6 (3000)
Metred Flow Adjustment Range L/min (U.S.GPM)	10: 0.3-10 (.08-2.6) 30: 0.3-30 (.08-7.9)	60: 2-60 (.53-15.9) 125: 2-125 (.53-33)	3-250 (.79-66)	5-500 (1.32-132)
Min. Differential Pres. MPa (PSI)	0.6 (90)	1.0 (145)	1.3 (190)	2.0 (290)
Free Flow (EFCG Models Only.) L/min (U.S.GPM)	40 (10.6)	130 (34.3)	280 (74.0)	550 (145)
Rated Current	600 mA	600 mA	600 mA	700 mA
Coil Resistance	45 Ω	45 Ω	45 Ω	45 Ω
Hysteresis	5% or less	7% or less	7% or less	7% or less
Repeatability	1% or less	1% or less	1% or less	1% or less
Approx. Mass kg (lbs.)	8.2 (18.1)	12.5 (27.6)	25 (55.1)	51 (113)

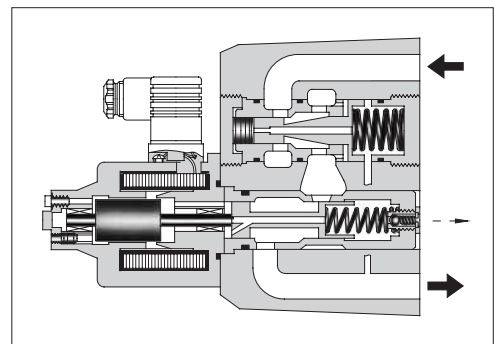

Graphic Symbols

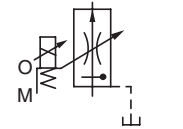

EFG-\*

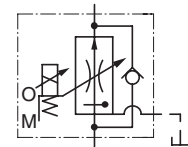

EFCG-\*

★ Min. pressure difference required between inlet and outlet ports to maintain function as pressure compensator.

### Model Number Designation

F-	EFC	G	-02	-10	-31	*
Special Seals	Series Number	Type of Mounting	Valve Size	Max. Metred Flow L/min (U.S.GPM)	Design Number	Design Standards
F: Special Seals for Phosphate Ester Type Fluid (Omit if not required)	EF: Proportional Electro-Hydraulic Flow Control Valve EFC: Proportional Electro-Hydraulic Flow Control and Check Valve	G: Sub-plate Mounting	02	10: 10 (2.6) 30: 30 (7.9)	31	Refer to ★
			03	60: 60 (15.9) 125: 125 (33)		
			06	250: 250 (66)		
			10	500: 500 (132)		

Note: If you are going to use the model with pressure compensator stroke adjustment screw, consult your Yuken representative in advance.

★ Design Standards: None ..... Japanese Standard "JIS" and European Design Standard 90 ..... N. American Design Standard

## Attachment

### Mounting Bolts

Valve Model Numbers	Socket Head Cap Screw		Qty.
	Japanese Std. "JIS" and European Design Std.	N. American Design Std.	
EF*G-02	M8 × 75 Lg.	5/16-18 UNC × 3 Lg.	4
EF*G-03	M10 × 100 Lg.	3/8-16 UNC × 4 Lg.	4
EF*G-06	M16 × 130 Lg.	5/8-11 UNC × 5 Lg.	4
EF*G-10	M20 × 160 Lg.	3/4-10 UNC × 6-1/2 Lg.	4

## Applicable Power Amplifiers

For stable performance, it is recommended that Yuken's applicable power amplifiers be used (for details see [page 772](#)).

Model Numbers : AME-D-\* -40

AME-DF-S- \*-22

AME-T-S- \*-22

## Sub-plate

Valve Model Numbers	Japanese Standard "JIS"		European Design Standard		N. American Design Standard		Approx. Mass kg (lbs.)
	Sub-plate Model Numbers	Thread Size	Sub-plate Model Numbers	Thread Size	Sub-plate Model Numbers	Thread Size	
EFG EFCG -02	EFGM-02X-20	Rc 3/8	EFGM-02X-2080	3/8 BSP.F	EFGM-02X-2090	3/8 NPT	2.3 (5.1)
	EFGM-02Y-20	Rc 1/2	EFGM-02Y-2080	1/2 BSP.F	EFGM-02Y-2090	1/2 NPT	3.1 (6.8)
EFG EFCG -03	EFGM-03Y-20	Rc 3/4	EFGM-03Y-2080	3/4 BSP.F	EFGM-03Y-2090	3/4 NPT	5.7 (12.6)
	EFGM-03Z-20	Rc 1	EFGM-03Z-2080	1 BSP.F	EFGM-03Z-2090	1 NPT	5.6 (12.3)
EFG EFCG -06	EFGM-06X-20	Rc 1	EFGM-06X-2080	1 BSP.F	EFGM-06X-2090	1 NPT	12.5 (27.6)
	EFGM-06Y-20	Rc 1-1/4	EFGM-06Y-2080	1-1/4 BSP.F	EFGM-06Y-2090	1-1/4 NPT	16 (35.3)
EFG EFCG -10	EFGM-10Y-10 <sup>★</sup>	1-1/2, 2 Flange Mounting	EFGM-10Y-1080 <sup>★</sup>	1-1/2, 2 Flange Mounting	EFGM-10Y-1090 <sup>★</sup>	1-1/2, 2 Flange Mounting	37 (81.6)

● Sub-plates are available. Specify the sub-plate model number from the table above. When sub-plates are not used, the mounting surface should have a good machined finish.

★ When ordering the EFGM-10Y, see Type F3 Pipe Flange Kits on [page 821](#) and order an appropriate pipe flange kit also.

## Models with Pressure Compensator Stroke Adjustment Screw

A models with pressure compensator stroke adjustment screw is optionally available to minimize the actuator protrusion (jumping) at startup. For the details, please consult us or your Yuken distributors.

## Instructions

### Drain Back Pressure

Check that the drain back pressure does not exceed 0.2 MPa (29 PSI).

### Models with Check Valve

A models with check valve makes it possible to obtain a free flow in the direction opposite that of the controlled flow without respect to the input current.

**EFG/EF CG-02- \*-31/3190**  
**EFG/EF CG-03- \*-26/2690**

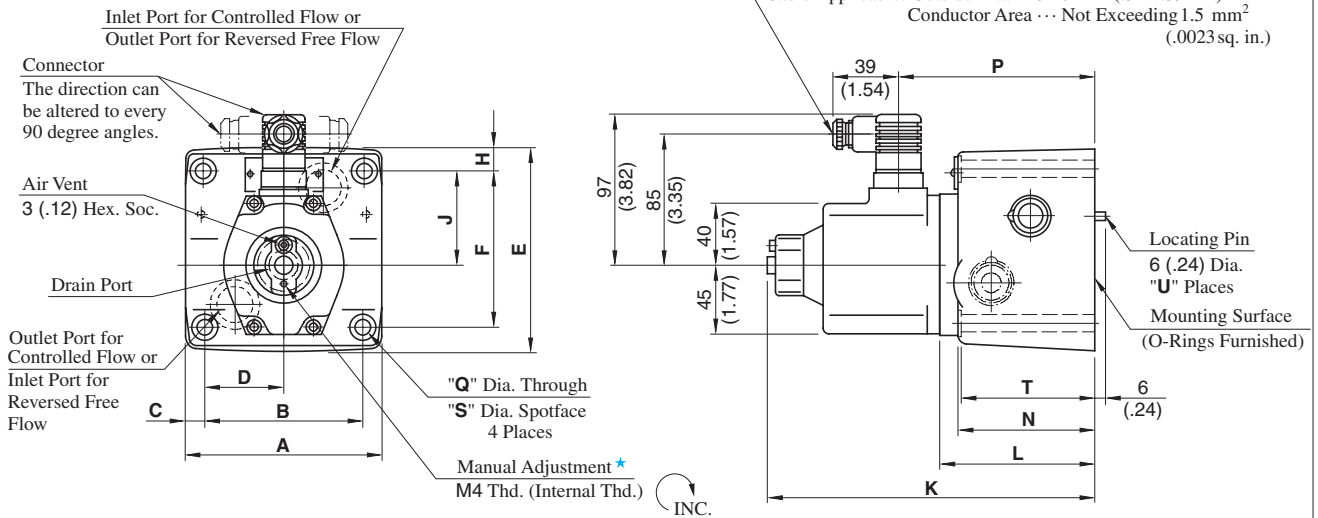

★ Manual adjustment can be done by screwing for example an M4×20 L screw in the M4 thread or pushing in a rod etc. there.

Model Numbers	Dimensions mm (Inches)															U
	A	B	C	D	E	F	H	J	K	L	N	P	Q	S	T	
EF*G-02	96 (3.78)	76.2 (3.00)	9.9 (.39)	38.1 (1.50)	106 (4.17)	82.6 (3.25)	11.7 (.46)	46.3 (1.82)	195 (7.68)	81 (3.19)	66 (2.60)	108 (4.25)	8.8 (.35)	14 (.55)	65 (2.56)	1
EF*G-03	125 (4.92)	101.6 (4.00)	11.7 (.46)	50.8 (2.00)	130 (5.12)	101.6 (4.00)	14.2 (.56)	61.8 (2.43)	212 (8.35)	98 (3.86)	85 (3.35)	125 (4.92)	11 (.43)	17.5 (.69)	84 (3.31)	2

**EFG/EF CG-06-250-22/2290**  
**EFG/EF CG-10-500-11/1190**

**DIMENSIONS IN MILLIMETRES (INCHES)**

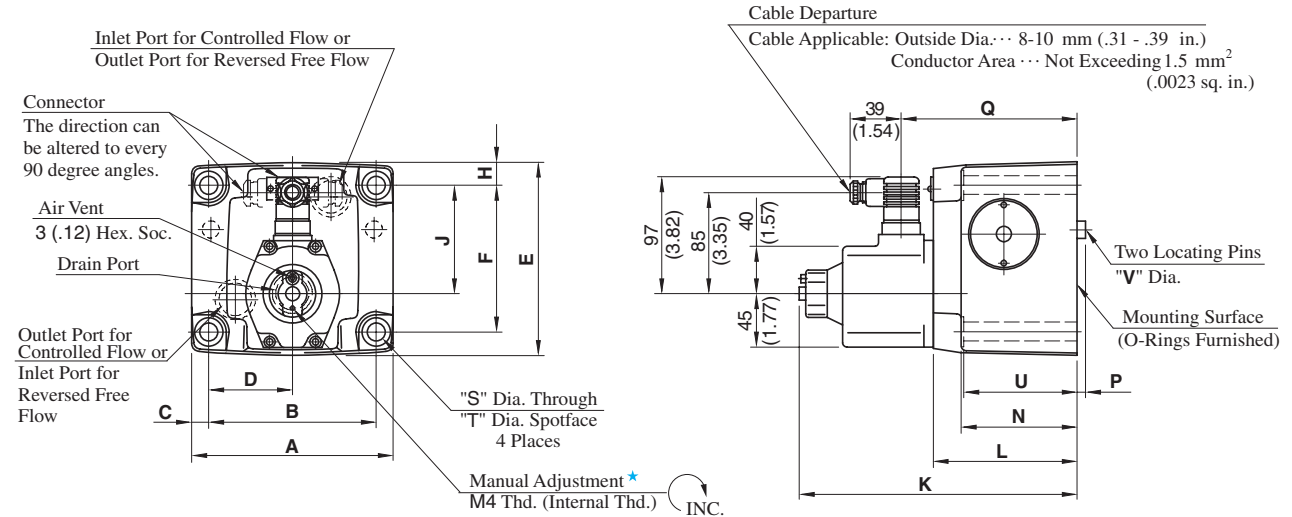

★ Manual adjustment can be done by screwing for example an M4×20 L screw in the M4 thread or pushing in a rod etc. there.

Model Numbers	Dimensions mm (Inches)																
	A	B	C	D	E	F	H	J	K	L	N	P	Q	S	T	U	V
EF*G-06	180 (7.09)	146.1 (5.75)	17 (.67)	73.1 (2.88)	174 (6.85)	133.4 (5.25)	20.3 (.80)	99 (3.90)	244 (9.61)	130 (5.12)	105 (4.13)	7 (.28)	157 (6.18)	17.5 (.69)	26 (1.02)	103.5 (4.07)	16 (.63)
EF*G-10	244 (9.61)	196.9 (7.75)	23.5 (.93)	98.5 (3.88)	228 (8.98)	177.8 (7.00)	25 (.98)	144.5 (5.69)	274 (10.79)	160 (6.30)	137 (5.93)	10 (.39)	187 (7.36)	21.5 (.85)	32 (1.26)	135 (5.31)	18 (.71)

**H**  
**E Series**  
**40Ω Series Flow Control (and Check) Valves**



■ Sub-plate  
EFGM-06X/06Y-20/2080/2090

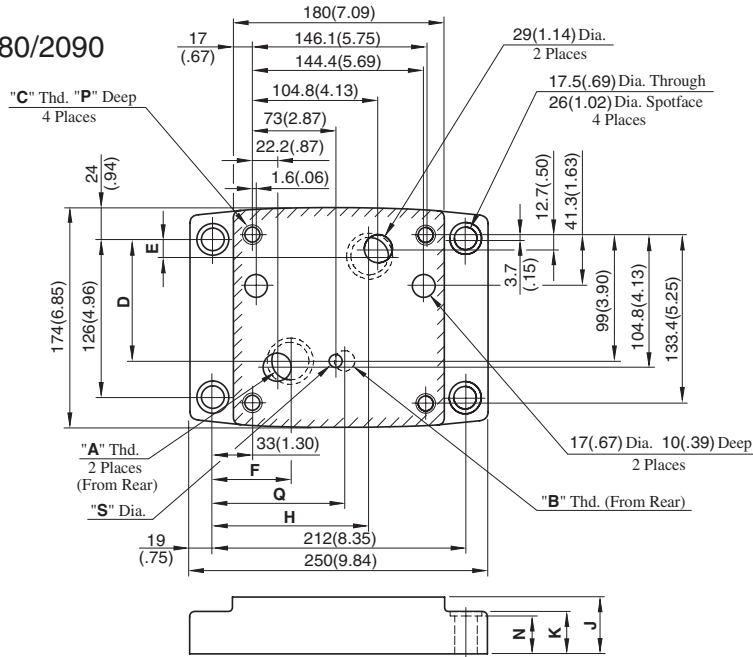

Sub-plate Model Numbers	Thread Size			Dimensions mm (Inches)									
	"A" Thd.	"B" Thd.	"C" Thd.	D	E	F	H	J	K	N	P	Q	S
EFGM-06X-20	Rc 1	Rc 3/8	M16	101.1 (3.98)	14.3 (.56)	55.2 (2.17)	137.8 (5.43)	45 (1.77)	35 (1.38)	34 (1.34)	30 (1.18)	106 (4.17)	14 (.55)
EFGM-06Y-20	Rc 1-1/4			95.3 (3.75)	19.3 (.76)	67 (2.64)	132 (5.20)	60 (2.36)	40 (1.57)	39 (1.54)			
EFGM-06X-2080	1 BSP.F	3/8 BSP.F		101.1 (3.98)	14.3 (.56)	55.2 (2.17)	137.8 (5.43)	45 (1.77)	35 (1.38)	34 (1.34)	35 (1.38)	106 (4.17)	14 (.55)
EFGM-06Y-2080	1-1/4 BSP.F			95.3 (3.75)	19.3 (.76)	67 (2.64)	132 (5.20)	60 (2.36)	40 (1.57)	39 (1.54)			
EFGM-06X-2090	1 NPT	3/8 NPT	5/8-11 UNC	101.1 (3.98)	14.3 (.56)	55.2 (2.17)	137.8 (5.43)	45 (1.77)	35 (1.38)	34 (1.34)	35 (1.38)	106 (4.17)	14 (.55)
EFGM-06Y-2090	1-1/4 NPT			95.3 (3.75)	19.3 (.76)	67 (2.64)	132 (5.20)	60 (2.36)	40 (1.57)	39 (1.54)			

DIMENSIONS IN MILLIMETRES (INCHES)

EFGM-10Y-10/1080/1090

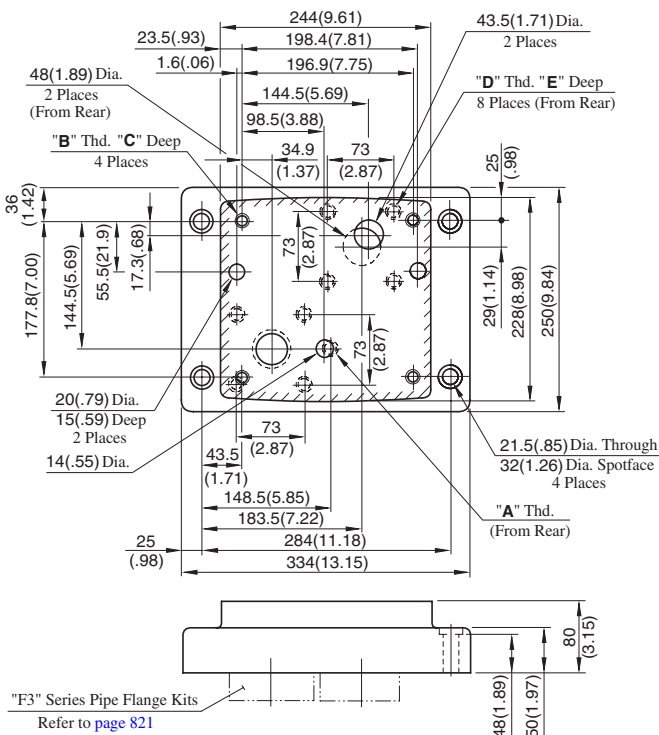

Sub-plate Model Numbers	Thread Size		
	"A" Thd.	"B" Thd.	"D" Thd.
EFGM-10Y-10	Rc 3/8	M20	M16
EFGM-10Y-1080	3/8 BSP.F		
EFGM-10Y-1090	3/8 NPT	3/4-10 UNC	5/8-11 UNC

Sub-plate Model Numbers	mm (Inches)	
	C	E
EFGM-10Y-10	30 (1.18)	30 (1.18)
EFGM-10Y-1080	34 (1.34)	35 (1.38)
EFGM-10Y-1090	34 (1.34)	35 (1.38)

"F3" Series Pipe Flange Kits  
Refer to page 821

**Input Current vs. Flow**

Viscosity: 30 mm<sup>2</sup>/s  
(141 SSU)

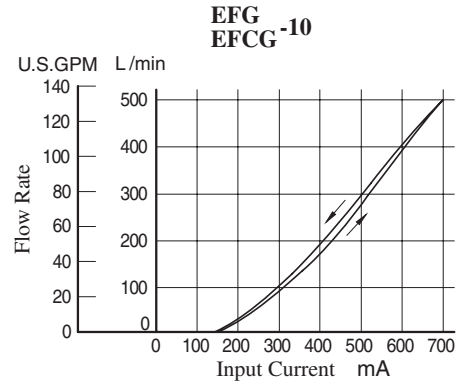
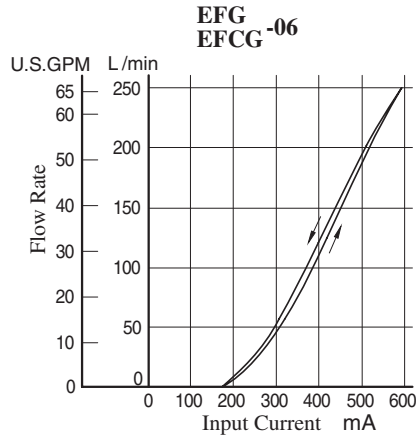
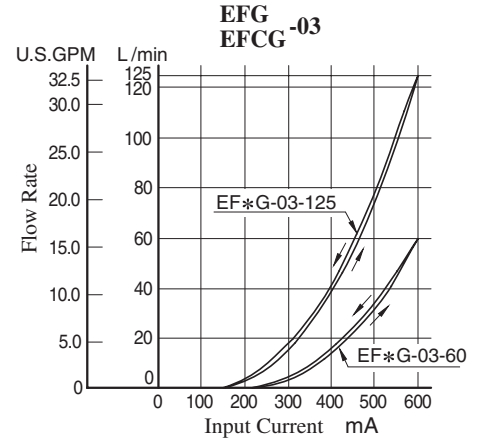
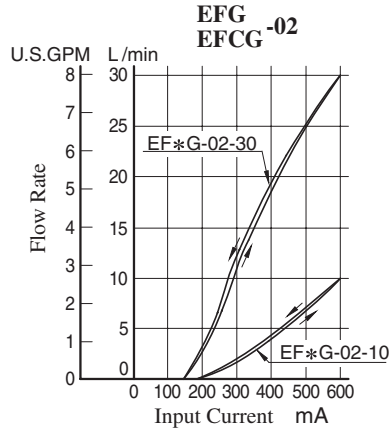

**Differential Pressure vs. Metred Flow**

Viscosity: 30 mm<sup>2</sup>/s  
(141 SSU)

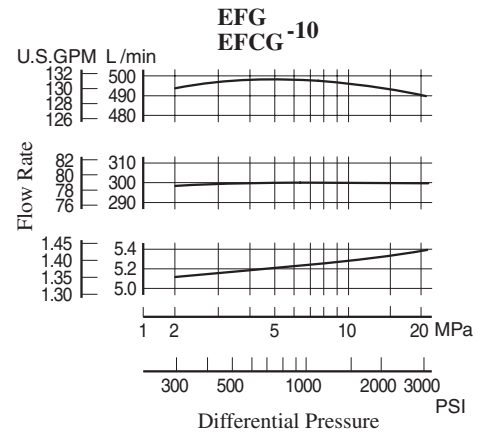
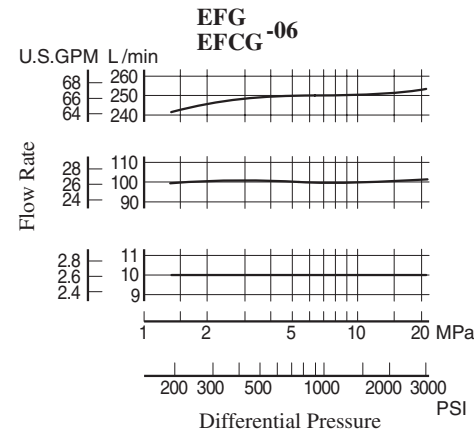
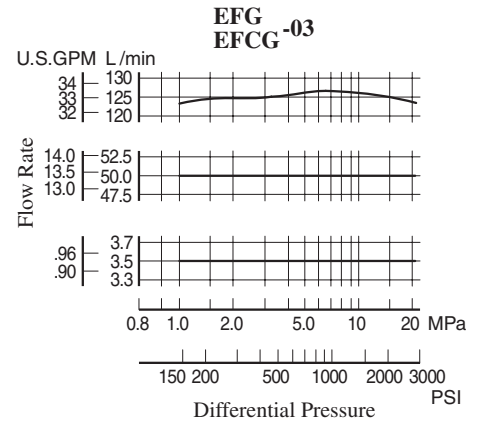
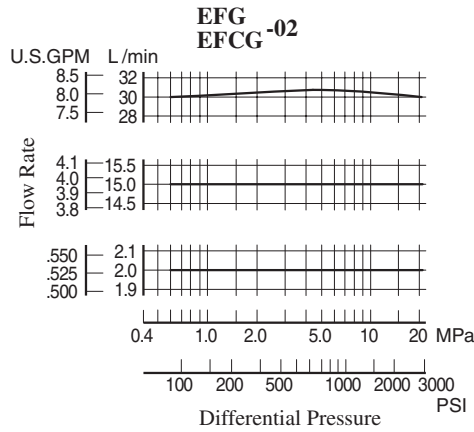

**Step Response**

Viscosity: 30 mm<sup>2</sup>/s (141 SSU)

These characteristics have been obtained by measuring on each valve. Therefore, they may vary according to a hydraulic circuit to be used.

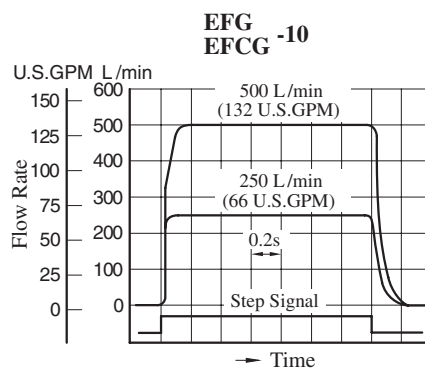
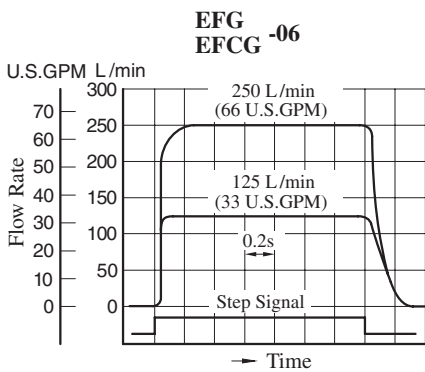
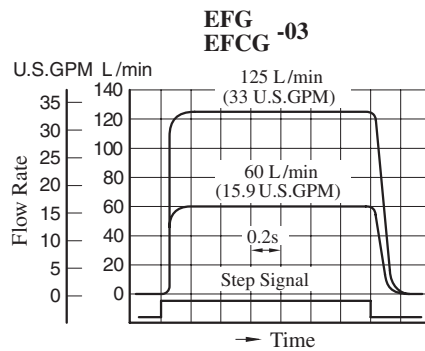
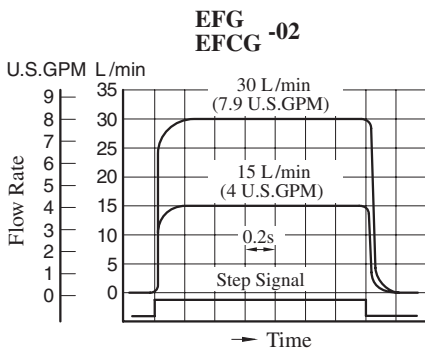

**Frequency Response**

Viscosity: 30 mm<sup>2</sup>/s (141 SSU)

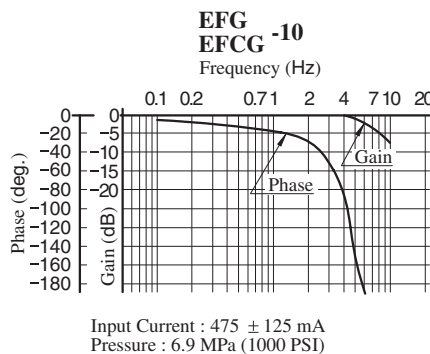
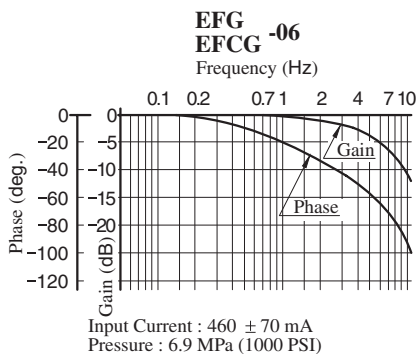
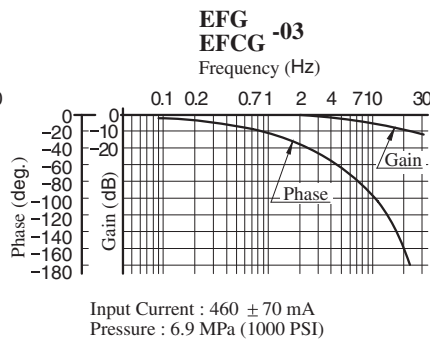
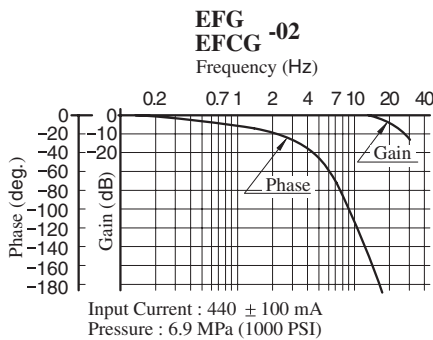

**Viscosity vs. Flow**

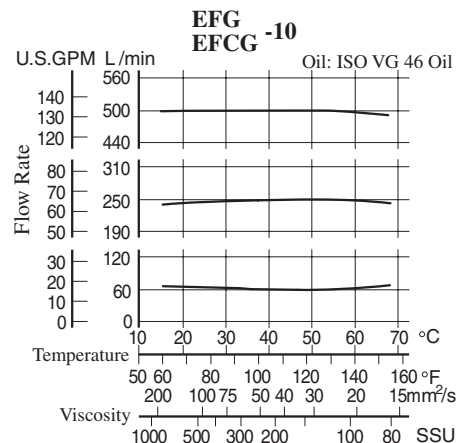
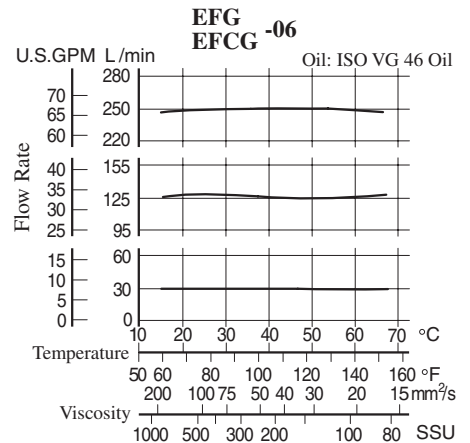
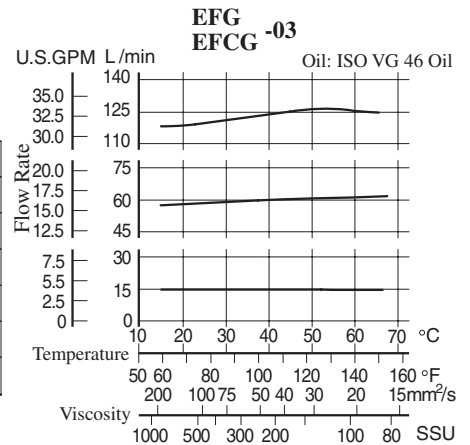
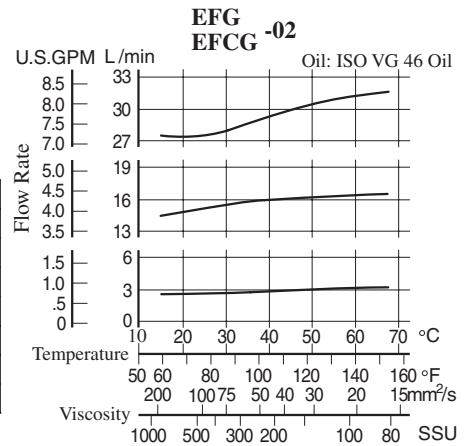

■ Pressure Drop for Reversed Free Flow (Only for "EFCG" Models)

Oil Viscosity: 35 mm<sup>2</sup>/s (164 SSU)  
 Specific Gravity: 0.850

**EFCG-02**

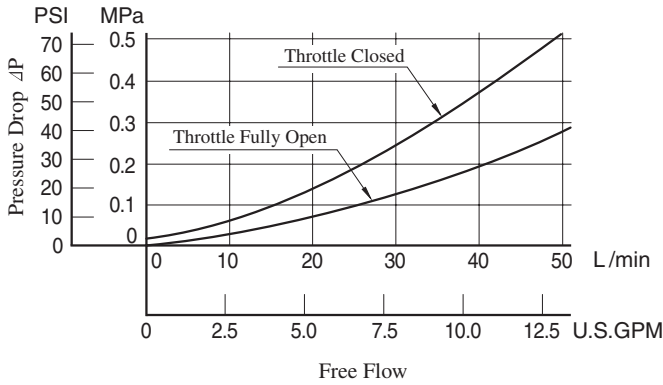

**EFCG-03**

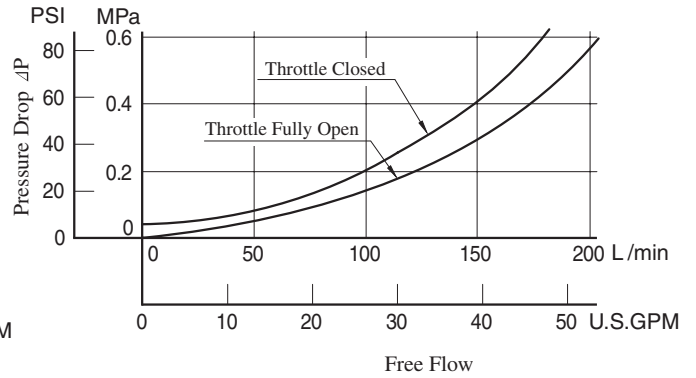

**EFCG-06**

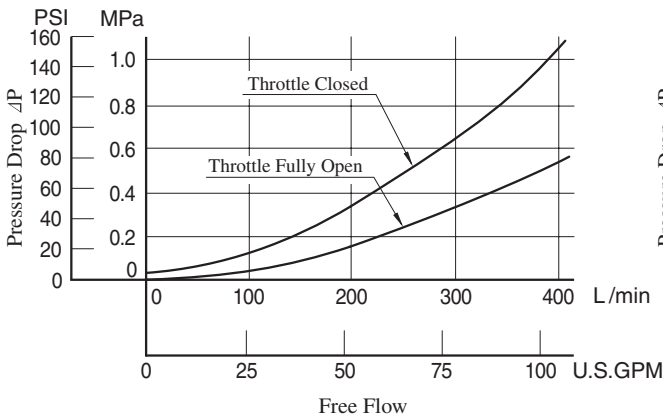

**EFCG-10**

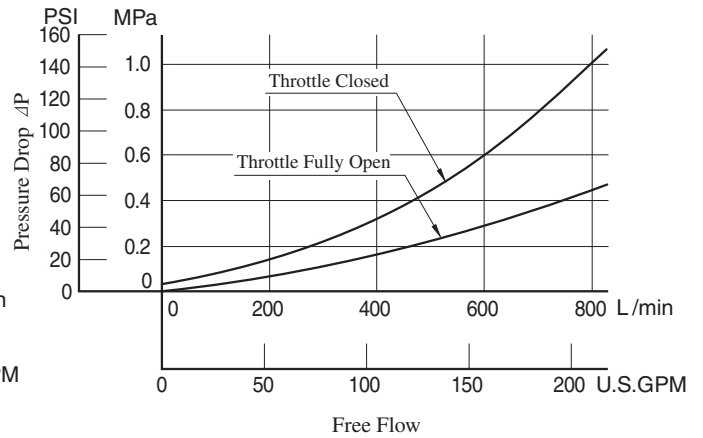

● For any other viscosity, multiply the factors in the table below.

Viscosity	mm <sup>2</sup> /s	20	40	60	80	100
	SSU	98	186	278	371	464
Factor		0.87	1.03	1.14	1.23	1.30

● For any other specific gravity (G'), the pressure drop (ΔP') may be obtained from the formula below.  
 $\Delta P' = \Delta P (G'/0.850)$



List of Seals and Solenoid Ass'y

EFG/EFCG-02- \*-31/3190  
EFG/EFCG-03- \*-26/2690

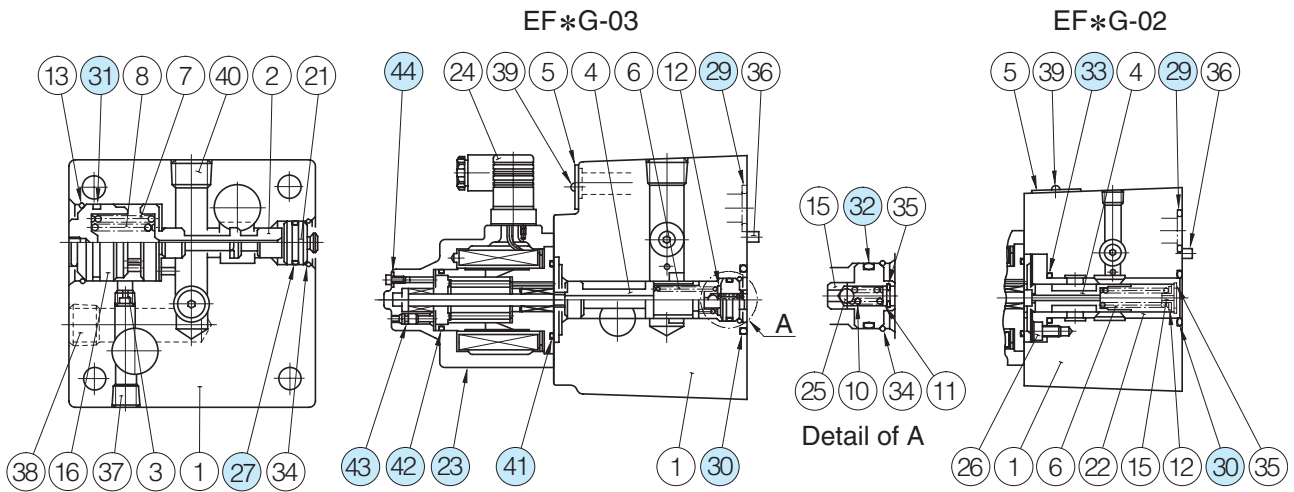

With Check Valve (EFCG-02, 03)

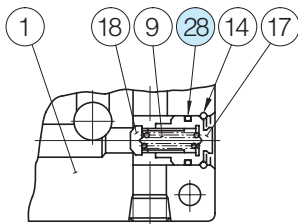

List of Seals and Solenoid Ass'y

Item	Name of Parts	Part Numbers		Qty.
		EF*G-02	EF*G-03	
23	Solenoid Ass'y	E321-45-20	E321-45-20	1
27	O-Ring	SO-NB-P18	SO-NB-P18	1
28	O-Ring	SO-NB-P10A	SO-NB-P21	1
29	O-Ring	SO-NB-P18	SO-NB-P28	2
30	O-Ring	SO-NB-P22	SO-NB-P31	1
31	O-Ring	SO-NB-G25	SO-NB-G35	1
32	O-Ring	—	SO-NB-P18	1
33	O-Ring	SO-NB-P22	—	1
41	O-Ring	SO-NB-G45	SO-NB-G45	1
42	O-Ring	SO-NB-G35	SO-NB-G35	1
43	O-Ring	SO-NA-P4	SO-NA-P4	1
44	Fastener Seal	SG-FCF-4	SG-FCF-4	1

- Note 1: O-rings (Item 41, 42, 43) and the fastener seal (Item 44) are included in the solenoid assembly.  
 2: The connector assembly GDM-211-B-11 (Item 24) is not included in the solenoid assembly.  
 3: When ordering seals, please specify the seal kit number from the table right.

List of Seal Kits

Valve Model Numbers	Seal Kit Numbers
EFG-02- *-31 *	KS-EFG-02-31
EFCG-02- *-31 *	KS-EFCG-02-31
EFG-03- *-26 *	KS-EFG-03-26
EFCG-03- *-26 *	KS-EFCG-03-26

■ List of Seals and Solenoid Ass'y

EFG/EFCG-06-250-22/2290  
EFG/EFCG-10-500-11/1190

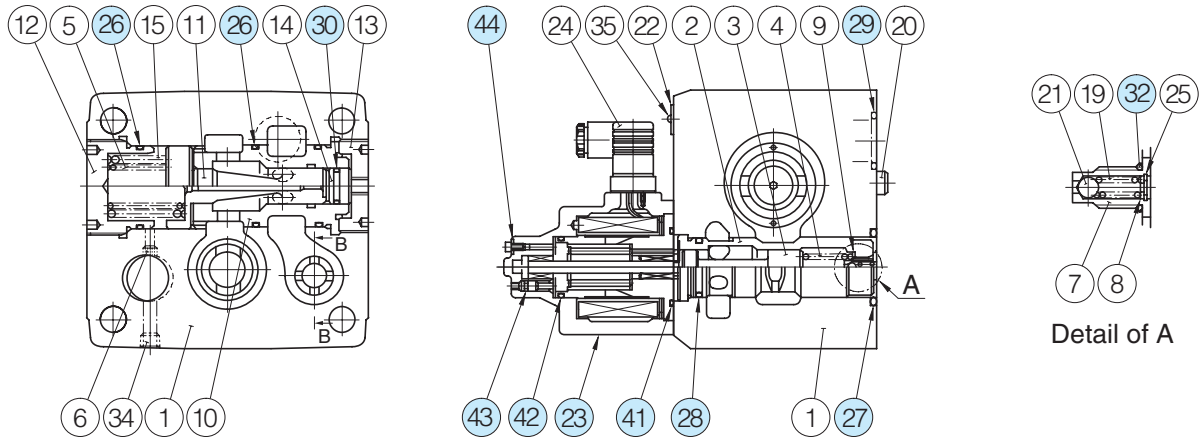

With Check Valve (EFCG-06, 10)

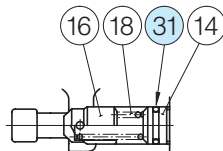

Section B-B

● List of Seals and Solenoid Ass'y

Item	Name of Parts	Part Numbers		Qty.
		EF*G-06	EF*G-10	
23	Solenoid Ass'y	E321-45-20	E321-45-20	1
26	O-Ring	SO-NB-P50	SO-NB-G75	3
27	O-Ring	SO-NB-P44	SO-NB-G60	1
28	O-Ring	SO-NB-P34	SO-NB-P50	1
29	O-Ring	SO-NB-P32	SO-NB-P48	2
30	O-Ring	SO-NB-P21	SO-NB-P34	1
31	O-Ring	SO-NB-P21	SO-NB-P26	1
32	O-Ring	SO-NA-P10	SO-NA-P10	1
41	O-Ring	SO-NB-G45	SO-NB-G45	1
42	O-Ring	SO-NB-G35	SO-NB-G35	1
43	O-Ring	SO-NA-P4	SO-NA-P4	1
44	Fastener Seal	SG-FCF-4	SG-FCF-4	1

● List of Seal Kits

Valve Model Numbers	Seal Kit Numbers
EFG-06-250-22*	KS-EFG-06-22
EFCG-06-250-22*	KS-EFCG-06-22
EFG-10-500-11*	KS-EFG-10-11
EFCG-10-500-11*	KS-EFCG-10-11

Note1: O-rings (Item 41, 42, 43) and the fastener seal (Item 44) are included in the solenoid assembly.

2: The connector assembly GDM-211-B-11 (Item 24) is not included in the solenoid assembly.

3: When ordering seals, please specify the seal kit number from the table right.

## 10Ω Series Proportional Electro-Hydraulic Flow Control (and Check) Valves

Since the preselected flow rate continuously varies in proportion to the current input to the valve, the system flow rate can be remote-controlled as desired by regulating the current output from the amplifier. Further, since the pressure and temperature compensation functions are provided, the preselected flow rate is not affected by pressure (load) or temperature (fluid viscosity). This valve is ideal for use where actuator startup, stop, and speed changes are to be implemented without producing a shock. Note that this valve is used in conjunction with the applicable power amplifier.



### Specifications

Model No.		EFG EFCG -03- 60 EFCG -03-125	EFG EFCG -06-250
Description			
Max. Operating Pressure MPa (PSI)		20.6 (3000)	24.5 (3550)
Metred Flow Adj. Range L/min (U.S.GPM)		60: 1-60 (.26-15.9) 125: 1-125 (.26-33)	2.5-250 (.66-66)
Min. Differential Pressure <sup>★1</sup> MPa (PSI)		1.0 (145)	1.0 (145)
Free Flow (EFCG Models Only) L/min (U.S.GPM)		130 (34.3)	280 (74.0)
Min. Pilot Pressure <sup>★2</sup> MPa (PSI)		1.0 (145)	1.5 (220)
Pilot Flow L/min (U.S.GPM)	at Normal	0.5 (.13)	1 (.26)
	at Transition	2.6 (.69)	4 (1.06)
Rated Current		780 mA	820 mA
Coil Resistance		10 Ω	10 Ω
Hysteresis		3% or less	3% or less
Repeatability		1% or less	1% or less
Approx. Mass	kg (lbs.)	10 (22.1)	25 (55.1)

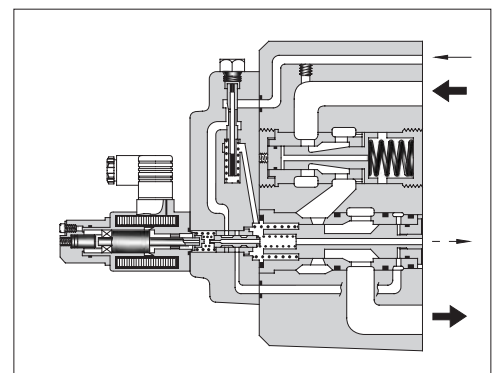

### Graphic Symbols

Internal Pilot

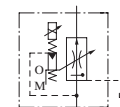

EFG- \*

External Pilot

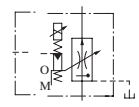

EFG- \*

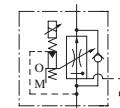

EFCG- \*

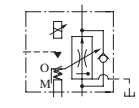

EFCG- \*

- ★1. Min pressure difference required between inlet and outlet ports to maintain function as pressure compensator.
- ★2. The minimum required value for the external pilot type.

### Model Number Designation

F-	EFC	G	-03	-125	-E	-51	*
Special Seals	Series Number	Type of Mounting	Valve Size	Max. Metred Flow L/min (U.S.GPM)	Pilot Connection	Design Number	Design Standards
<b>F:</b> Special Seals for Phosphate Ester Type Fluid (Omit if not required)	<b>EF:</b> Proportional Electro-Hydraulic Flow Control Valve  <b>EFC:</b> Proportional Electro-Hydraulic Flow Control and Check Valve	<b>G:</b> Sub-plate Mounting	<b>03</b>	<b>60:</b> 60 (15.9) <b>125:</b> 125 (33)	<b>None:</b> Internal Pilot  <b>E:</b> External Pilot	<b>51</b>	Refer to ★
			<b>06</b>	<b>250:</b> 250 (66)		<b>51</b>	

★ Design Standards: None..... Japanese Standard "JIS" and European Design Standard 90 ..... N. American Design Standard

**Attachment**

**Mounting bolts**

Valve Model Numbers	Socket Head Cap Screw		Qty.
	Japanese Std. "JIS" and European Design Std.	N. American Design Std.	
EF*G-03	M10 × 80 Lg.	3/8-16 UNC × 3-1/4 Lg.	4
EF*G-06	M16 × 130 Lg.	5/8-11 UNC × 5 Lg.	4

**Applicable Power Amplifiers**

For stable performance, it is recommended that Yuken's applicable power amplifiers be used (for details see [page 767, 771, 780](#)).

- Model Numbers: AME-D-10-\* -20
- AME-D2-1010-11
- SK1022-\* -\*-11
- SK1015-11 (For DC power supply)
- AMN-D-10 (For DC power supply)

**Sub-plate**

Valve Model Numbers	Japanese Standard "JIS"		European Design Standard		N. American Design Standard		Approx. Mass kg (lbs.)
	Sub-plate Model Numbers	Thread Size	Sub-plate Model Numbers	Thread Size	Sub-plate Model Numbers	Thread Size	
EFG EFCG <sup>-03</sup>	EFGM-03Y-30	Rc 3/4	EFGM-03Y-3080	3/4 BSP.F	EFGM-03Y-3090	3/4 NPT	5.7 (12.6)
	EFGM-03Z-30	Rc 1	EFGM-03Z-3080	1 BSP.F	EFGM-03Z-3090	1 NPT	5.6 (12.3)
EFG EFCG <sup>-06</sup>	EFGM-06X-30	Rc 1	EFGM-06X-3080	1 BSP.F	EFGM-06X-3090	1 NPT	12.5 (27.6)
	EFGM-06Y-30	Rc 1-1/4	EFGM-06Y-3080	1-1/4 BSP.F	EFGM-06Y-3090	1-1/4 NPT	16 (35.3)

● Sub-plates are available. Specify the sub-plate model number from the tabel above. When sub-plates are not used, the mounting surface should have a good machined finish.

**Instructions**

**Drain Back Pressure**

Check that the drain back pressure dose not exceed 0.2 MPa (29 PSI).

**Pilot Type Selection**

This valve is constructed so as to operate at a pre-determined pilot pressure. For the 03, a pilot pressure of 1 MPa (145 PSI) or higher is required. For the 06, the requied pilot pressure is 1.5 MPa (220 PSI) or higher. To obtain such a required pilot pressure, select the pilot type according to the circuit examples on the right.

①/②

Use the external pilot type (pilot connection code: E) whether a metre-in or metre-out circuit is employed.

③

Use the internal pilot type (pilot connection code: None)

④

Use the external pilot type (pilot connection code: E)

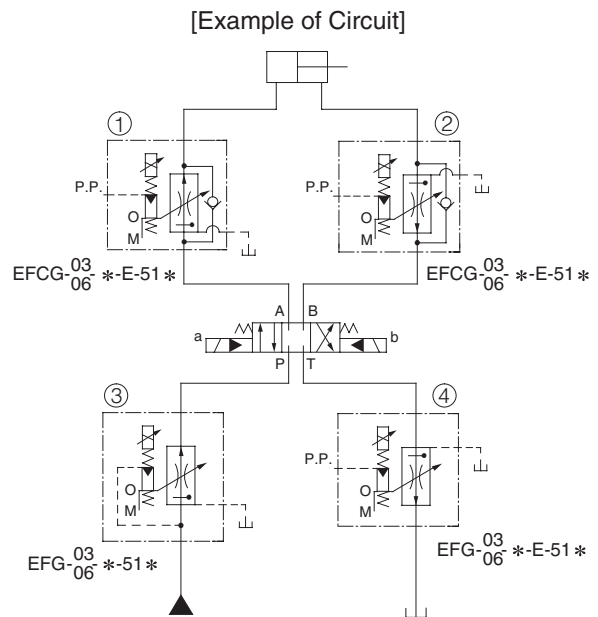

EFG -03- 60  
EFCG -03- 125 - \*-51/5190

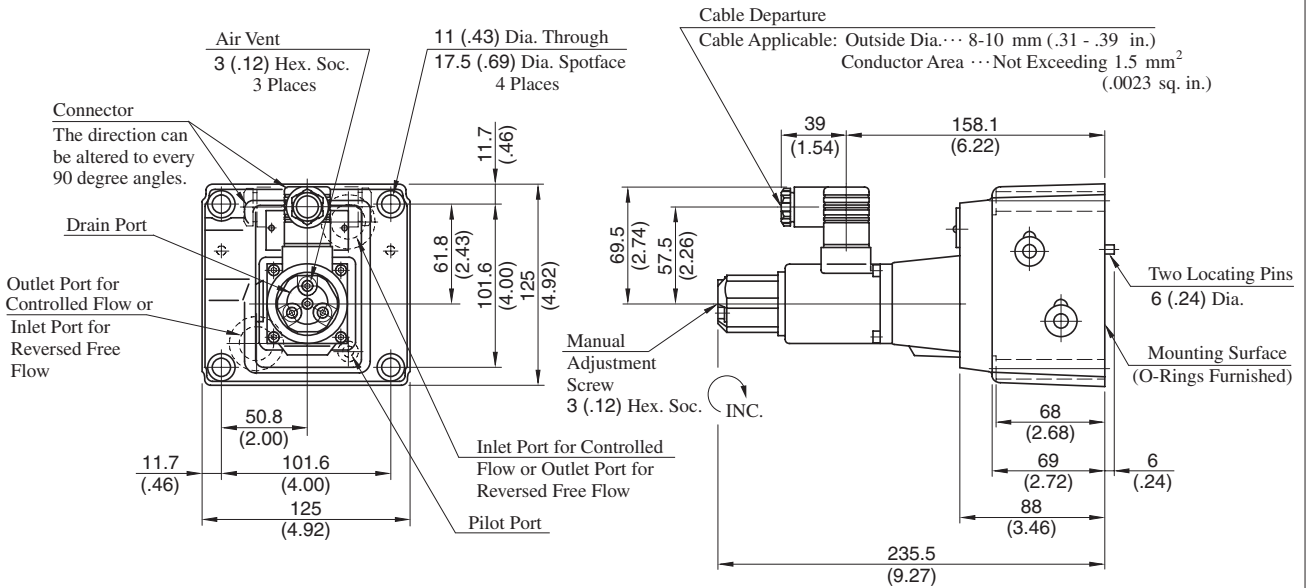

**DIMENSIONS IN MILLIMETRES (INCHES)**

EFG -06-250- \*-51/5190  
EFCG

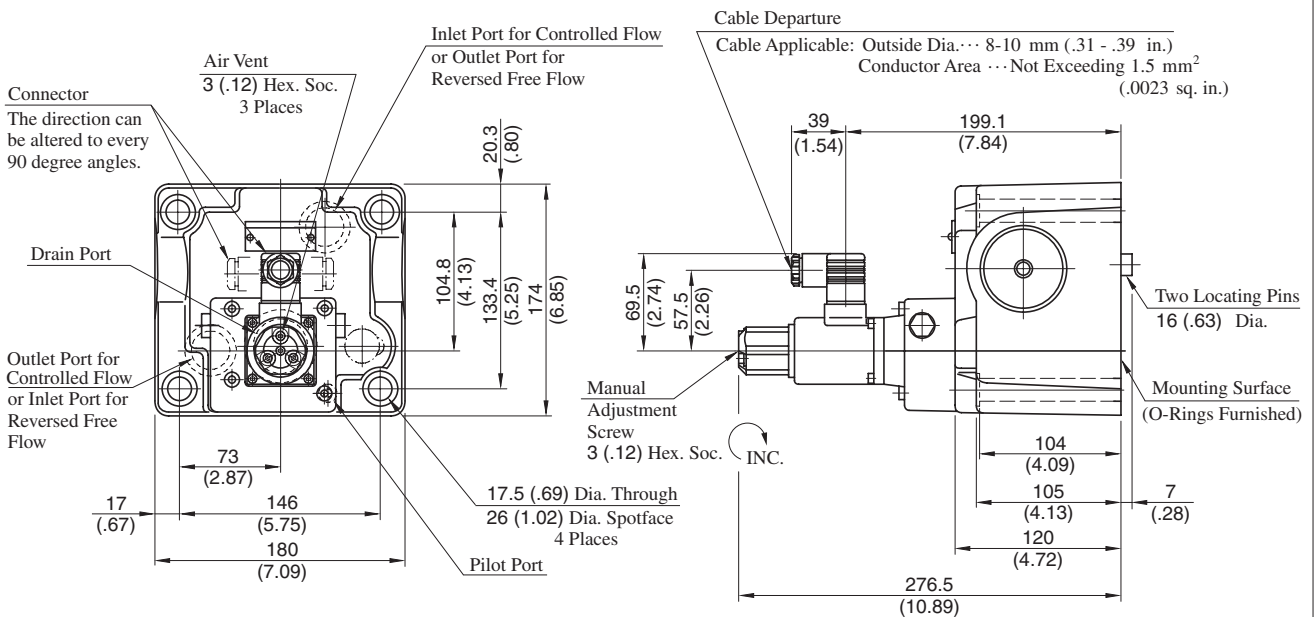

**H**  
E Series  
10Ω Series Flow Control (and Check) Valves

**Sub-plate**

**EFGM-03Y, 03Z-30/3080/3090**

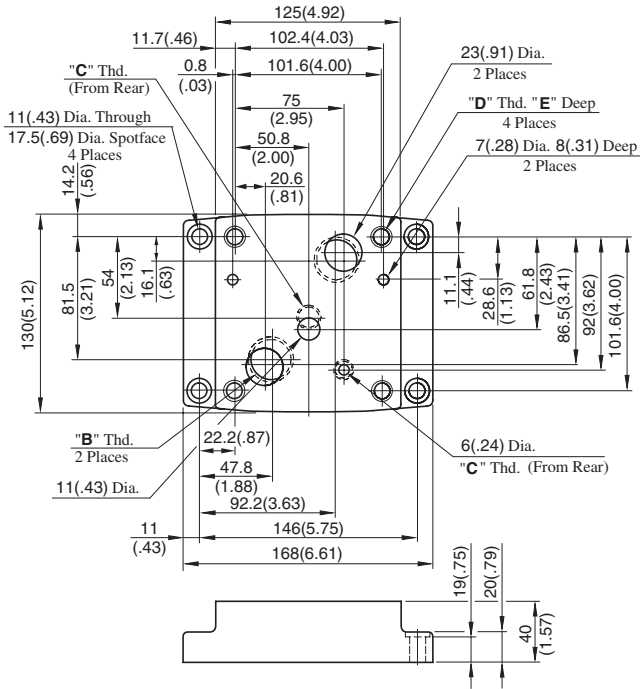

Sub-plate Model Numbers	Thread Size			E mm(in.)
	"B" Thd.	"C" Thd.	"D" Thd.	
EFGM-03Y-30	Rc 3/4	Rc 1/4	M10	18 (.71)
EFGM-03Z-30	Rc 1			
EFGM-03Y-3080	3/4 BSP.F	1/4 BSP.F	M10	21 (.83)
EFGM-03Z-3080	1 BSP.F			
EFGM-03Y-3090	3/4 NPT	1/4 NPT	3/8-16 UNC	21 (.83)
EFGM-03Z-3090	1 NPT			

DIMENSIONS IN MILLIMETRES (INCHES)

**EFGM-06X, 06Y-30/3080/3090**

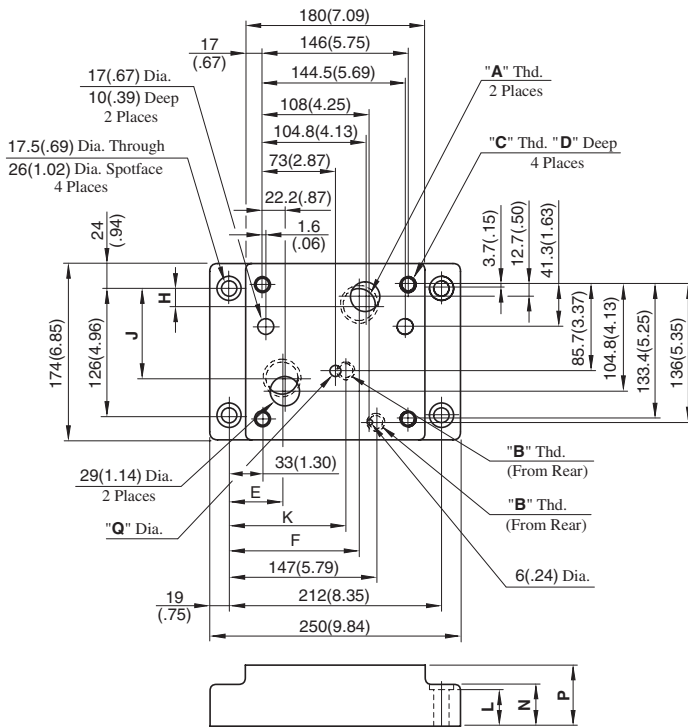

Sub-plate Model Numbers	Thread Size		
	"A" Thd.	"B" Thd.	"C" Thd.
EFGM-06X-30	Rc 1	Rc 3/8	M16
EFGM-06Y-30	Rc 1-1/4		
EFGM-06X-3080	1 BSP.F	3/8 BSP.F	M16
EFGM-06Y-3080	1-1/4 BSP.F		
EFGM-06X-3090	1 NPT	3/8 NPT	5/8-11 UNC
EFGM-06Y-3090	1-1/4 NPT		

Sub-plate Model Numbers	Dimensions mm (Inches)										
	D	E	F	H	J	K	L	N	P	Q	
EFGM-06X-30	30 (1.18)	55.2 (2.17)	137.8 (5.43)	14.3 (.56)	101.1 (3.98)	106 (4.17)	34 (1.34)	35 (1.38)	45 (1.77)	11 (.43)	
EFGM-06Y-30		52 (2.05)	132 (5.20)	19.3 (.76)	91.3 (3.59)		39 (1.54)	40 (1.57)	60 (2.36)		
EFGM-06X-3080		35 (1.38)	55.2 (2.17)	137.8 (5.43)	14.3 (.56)	101.1 (3.98)	116 (4.57)	34 (1.34)	35 (1.38)	45 (1.77)	15.2 (.60)
EFGM-06Y-3080			52 (2.05)	132 (5.20)	19.3 (.76)	91.3 (3.59)		39 (1.54)	40 (1.57)	60 (2.36)	
EFGM-06X-3090	35 (1.38)	55.2 (2.17)	137.8 (5.43)	14.3 (.56)	101.1 (3.98)	106 (4.17)	34 (1.34)	35 (1.38)	45 (1.77)	11 (.43)	
EFGM-06Y-3090		52 (2.05)	132 (5.20)	19.3 (.76)	91.3 (3.59)		39 (1.54)	40 (1.57)	60 (2.36)		

**Input Current vs. Flow**

Viscosity: 30 mm<sup>2</sup>/s  
(141 SSU)

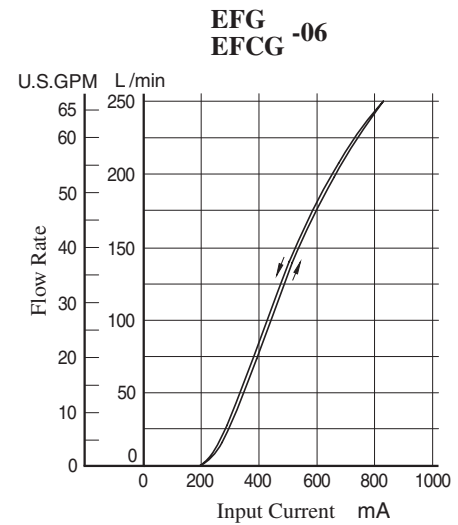
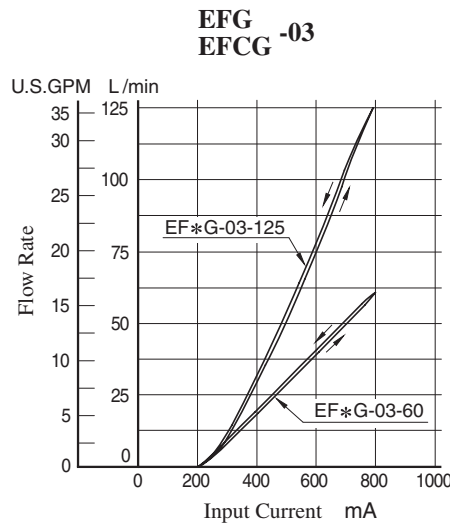

**Step Response**

These characteristics have been obtained by measuring on each valve. Therefore, they may vary according to a hydraulic circuit to be used.

Viscosity: 30 mm<sup>2</sup>/s  
(141 SSU)

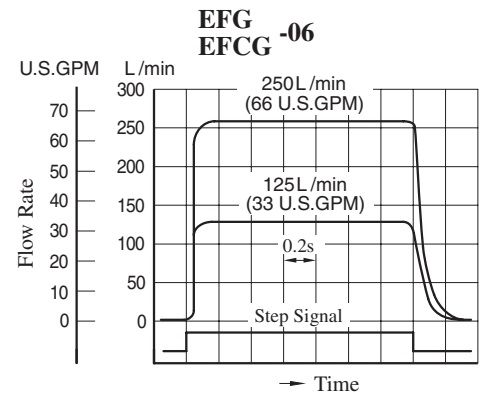
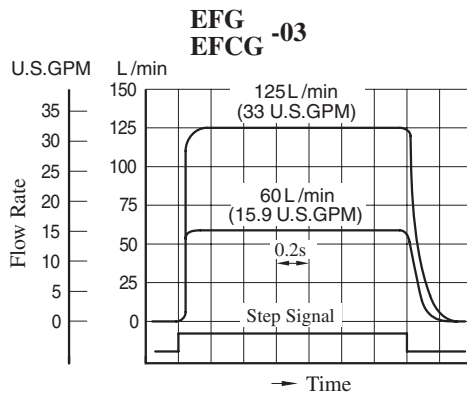

**Frequency Response**

Viscosity: 30 mm<sup>2</sup>/s  
(141 SSU)

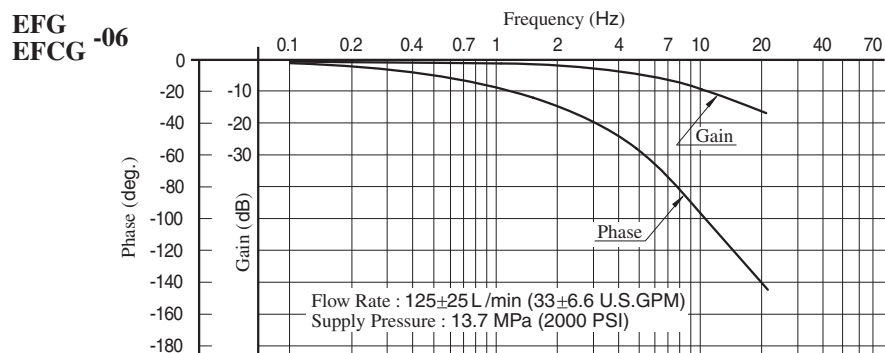
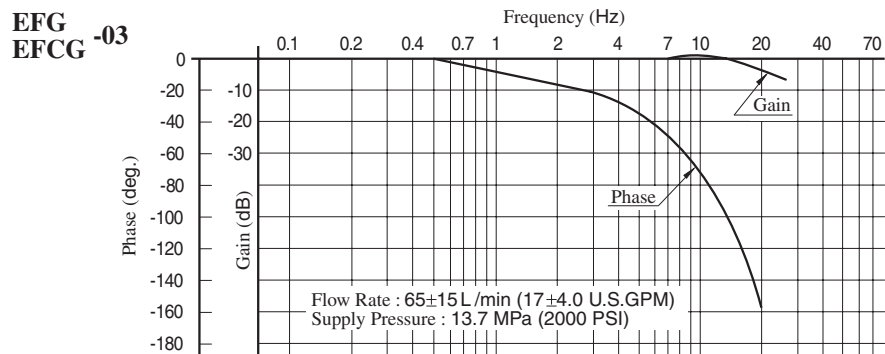

■ Viscosity vs. Flow

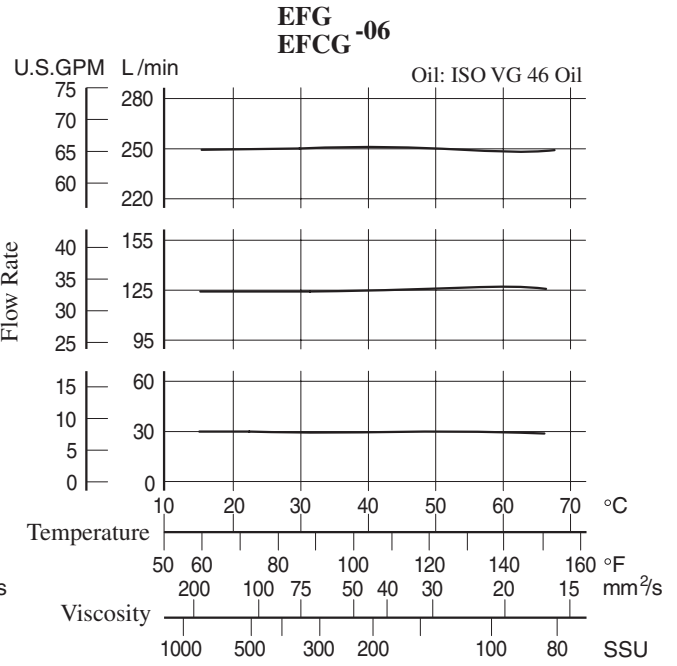
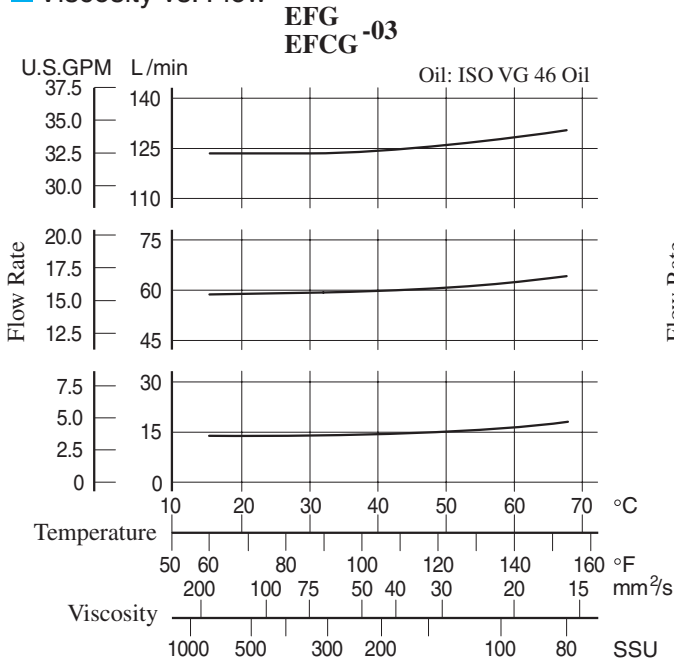

■ Differential Pressure vs. Metred Flow

**EFG  
EFCG -03**

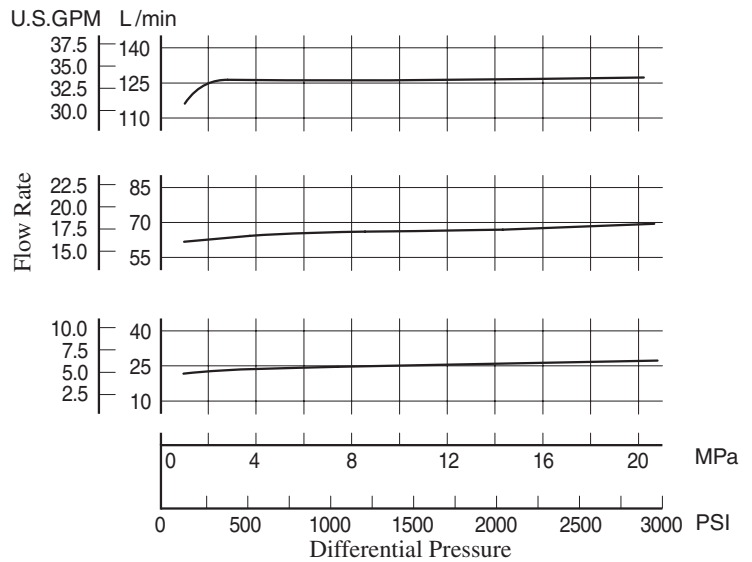

**EFG  
EFCG -06**

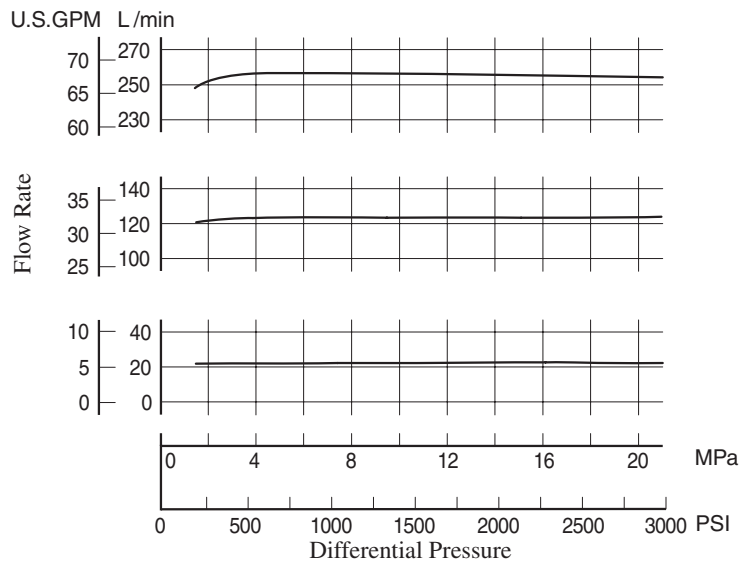



**List of Seals and Solenoid Ass'y**

EFG  
EFCG -03-\*-\*-51/5190

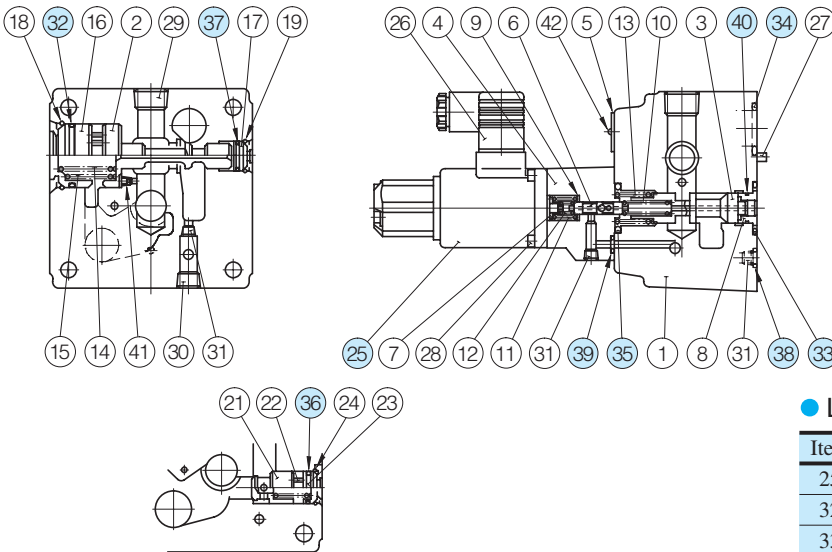

With Check Valve (EFCG-03)

Note: The connector assembly GDM-211-B-11 (Item 26) is not included in the solenoid assembly.

Note: When ordering seals, please specify the seal kit number from the table right. In addition to the right o-rings, seals for solenoid ass'y is included in the seal kit. For the detail of the solenoid ass'y seals, see [page 674](#).

● List of Seal Kits

Valve Model Numbers	Seal Kit Numbers
EFG-03-*-*-51*	KS-EFG-03-51
EFCG-03-*-*-51*	KS-EFCG-03-51

● List of Seals and Solenoid Ass'y

Item	Name of Parts	Part Numbers	Qty.
25	Solenoid Ass'y	E318-Y06M1-28-61	1
32	O-Ring	SO-NB-G35	1
33	O-Ring	SO-NB-P28	1
34	O-Ring	SO-NB-P28	2
35	O-Ring	SO-NB-P26	1
36	O-Ring	SO-NB-P16	1
37	O-Ring	SO-NB-P14	1
38	O-Ring	SO-NB-P9	1
39	O-Ring	SO-NB-P6	2
40	O-Ring	SO-NA-A016	1

EFG  
EFCG -06-250-\*-\*-51/5190

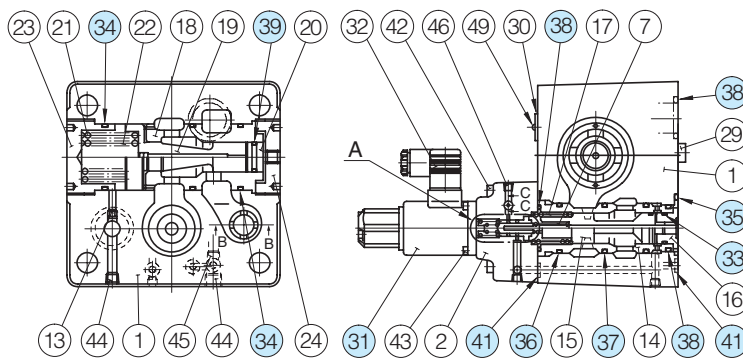

With Check Valve (EFCG-06)

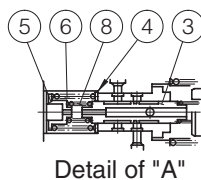

Detail of "A"

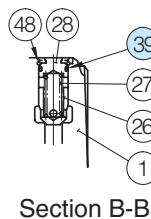

Section B-B

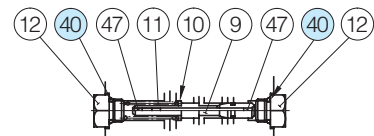

Detail of Section C-C

● List of Seal Kits

Valve Model Numbers	Seal Kit Numbers
EFG-06-250-*-*-51*	KS-EFG-06-51
EFCG-06-250-*-*-51*	KS-EFCG-06-51

● List of Seals and Solenoid Ass'y

Item	Name of Parts	Part Numbers	Qty.
31	Solenoid Ass'y	E318-Y06M1-28-61	1
33	O-Ring	SO-NA-P21	1
34	O-Ring	SO-NB-P50	3
35	O-Ring	SO-NB-P46	1
36	O-Ring	SO-NB-P36	1
37	O-Ring	SO-NB-P34	2
38	O-Ring	SO-NB-P32	4
39	O-Ring	SO-NA-P21	1*
40	O-Ring	SO-NB-P10	2
41	O-Ring	SO-NB-P9	3

★ Two O-rings are required for the EFCG.

Note: The connector assembly GDM-211-B-11 (Item 32) is not included in the solenoid assembly.

Note: When ordering seals, please specify the seal kit number from the table right. In addition to the right o-rings, seals for solenoid ass'y is included in the seal kit. For the detail of the solenoid ass'y seals, see [page 674](#).