

"A" Series Variable Displacement Piston Pumps – Single Pump, Pressure Compensator Type

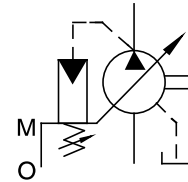

Graphic Symbol



Specifications

Model Numbers	Geometric Displacement cm ³ /rev (cu. in. /rev)	Minimum Adj. Flow cm ³ /rev (cu. in. /rev)	Operating Pressure MPa (PSI)		Shaft Speed Range r/min		Approx. Mass kg (lbs.)	
			Rated ^{*2}	Intermittent ^{*1}	Max.	Min.	Flange Mtg.	Foot Mtg.
A10-FR01B-12*	10.0 (.610)	2 (.122)	16 (2320)	21 (3050)	1800	600	5.1 (11.2)	—
A10-FR01C/H-12*							8.5 (18.7)	
A16-*-R-01-*-K-32*	15.8 (.964)	4 (.244)	16 (2320)	21 (3050)	1800	600	16.5 (36.4)	18.7 (41.2)
A22-*-R-01-*-K-32*	22.2 (1.355)	6 (.366)	16 (2320)	16 (2320)	1800	600	16.5 (36.4)	18.7 (41.2)
A37-*-R-01-*-K-32*	36.9 (2.25)	10 (.610)	16 (2320)	21 (3050)	1800	600	28.0 (61.7)	32.3 (71.2)
A56-*-R-01-*-K-32*	56.2 (3.43)	12 (.732)	16 (2320)	21 (3050)	1800	600	35.0 (77.2)	39.3 (86.7)
A70-*R01*S-60*	70.0 (4.27)	30 (1.83)	25 (3630)	28 (4060)	1800	600	58.5 (129)	70.5 (155)
A90-*R01*S-60*	91.0 (5.55)	56 (3.42)	25 (3630)	28 (4060)	1800	600	72.5 (160)	93 (205)
A145-*R01*S-60*	145 (8.85)	83 (5.06)	25 (3630)	28 (4060)	1800	600	92.5 (204)	117.5 (259)

- ★ 1. Whenever setting pressure, make sure the full cut-off pressure never exceeds the maximum intermittent pressure.
- ★ 2. Care should be taken in cases of used at a higher pressure than the rated pressure, because operating terms may be restricted. For example, if used as per maximum illustrated operating conditions, intermittent time at maximum flow is restricted to under 1/5 of one cycle time and under six seconds simultaneously. Conditions may vary according to the actual working pressure and delivery (inclination angle of the swash plate). Consult factory or Yuken sales representative for further information.
- ★ 3. The table above shows specifications for using petroleum based oils. Pumps (customized design) for special fluids are also available. Their operating pressure and maximum shaft speed however differ from the values in the table above depending on the fluid type. Range of operating temperature and viscosities may differ from those of petroleum based oils due to their characteristics.

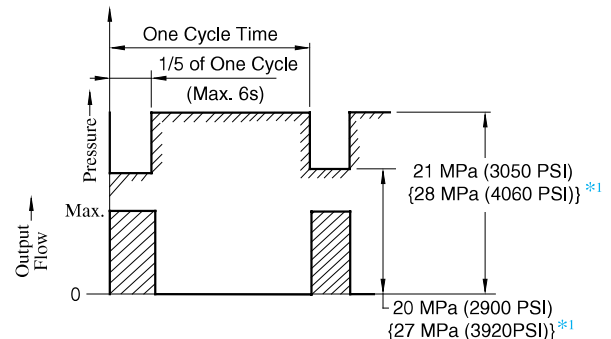

*1. Applicable only for "A70/90/145"

Specifications and Design numbers for Special Fluids

Type of Fluids	Pump Series	Operating Pressure MPa (PSI)		Allowable Maximum Shaft Speed r/min		Temperature Range °C (°F)	Viscosity Range mm ² /s (SSU)	Design Numbers for Special Fluid (Occasion of Japanese Std. "JIS") ^{*3}
		Rated	Intermittent	Rated	Max.			
Water-Glycols	A16 – A56	14(2030)	16(2320) {14(2030)} ^{*1}	1200	(1800) ^{*2}	0 - 50 (32 - 104)	20 - 200(98 - 927)	3230
	A70 – A145	21(3050)	21(3050)					6030
Phosphate Ester Type	A16 – A56	14(2030)	16(2320) {14(2030)} ^{*1}	1200	(1800) ^{*2}	0 - 60 (32 - 140)	20 - 200(98 - 927)	3206
	A70 – A145	21(3050)	21(3050)					6006
Polyol Ester Type	A16 – A56	16(2320)	16(2320)	1800	1800	0 - 60 (32 - 140)	20 - 200(98 - 927)	32450
	A70 – A145	21(3050)	21(3050)					60450

- ★ 1. The figures in brackets are for A22 type.
- ★ 2. As the specific gravities of water-glycol fluids and phosphate ester type fluids are higher than one, an overhead reservoir is required when pumps are operated at 1500 r/min or more.
- ★ 3. For the design numbers of pumps for European Design and North American Design Standards, please contact us.

Model Number Designation

A16	-F	-R	-01	-B	-S	-K	-32	*			
Series Number	Mounting	Direction of Rotation	Control Type	Pres. Adj. Range MPa (PSI)	Port Position	Shaft Extension	Design Number	Design Std.			
A16 (15.8 cm ³ /rev)	F: Flange Mtg.	(Viewed from Shaft End)	01: Pressure Compensator Type	B: 1.2 - 7 (170 - 1020) C: 1.2 - 16 (170 - 2320) H: 1.2 - 21 (170 - 3050)	None: Axial Port	K: Keyed Shaft	32	Refer to ^{*2}			
A22 (22.2 cm ³ /rev)				B: 1.2 - 7 (170 - 1020) C: 1.2 - 16 (170 - 2320)			32				
A37 (36.9 cm ³ /rev)				L: Foot Mtg.			R: Clockwise (Normal) ^{*1}		B: 1.2 - 7 (170 - 1020) C: 1.2 - 16 (170 - 2320) H: 1.2 - 21 (170 - 3050)	S: Side Port	32
A56 (56.2 cm ³ /rev)									B: 1.2 - 7 (170 - 1020) C: 1.2 - 16 (170 - 2320) H: 1.2 - 21 (170 - 3050)		32

A70	-F	R	01	B	S	-60	*
Series Number	Mounting	Direction of Rotation	Control Type	Pres. Adj. Range MPa (PSI)	Port Position	Design Number	Design Std.
A10 (10.0 cm ³ /rev)	F: Flange Mtg. ^{*3}	(Viewed from Shaft End)	01: Pressure Compensator Type	B: 1.2 - 7 (170 - 1020) ^{*4} C: 2.0 - 16 (290 - 2320) H: 2.0 - 21 (290 - 3050)	—	12	Refer to ^{*2}
A70 (70.0 cm ³ /rev)	F: Flange Mtg.			B: 1.2 - 7 (170 - 1020) C: 1.5 - 16 (220 - 2320) H: 1.8 - 21 (260 - 3050) K: 2.0 - 28 (290 - 4060)	S: Side Port	60	
A90 (91.0 cm ³ /rev)	L: Foot Mtg.			R: Clockwise (Normal) ^{*1}		60	
A145 (145 cm ³ /rev)						60	

- ★ 1. Available to supply pump with anti-clockwise rotation. Consult Yuken for details.
- ★ 2. Design Standards: None Japanese Standard "JIS"
80 European Design Standard
950 N. American Design Standard

- ★ 3. When A10 pump is used as the foot Mtg., order the Mtg. Bracket kit shown below separately. Refer to page 24 for dimensions of the Mtg. bracket.
Note: The mounting bracket kit consists of a mounting bracket, two hex. bolts and two plain washer.

Mtg. Bracket Kit Numbers	Approx. Mass kg (lbs.)
LP-1A-10	2.2 (4.9)

- ★ 4. The pressure adjustment range "B" is not available to the European Design Standard and the N. American Design Standard of "A10".

Pipe Flange Kits

Pipe flange kits are available. When ordering, specify the kit number from the table below.

Pump Model Numbers	Name of Port	Pipe Flange Kit Numbers						
		Threaded Connection			Socket Welding ^{*1}		Butt Welding	
		Japanese Std. "JIS"	European Design Std.	N. American Design Std. ^{*2}	Japanese Std. "JIS" European Design Std.	N. American Design Std. ^{*2}	Japanese Std. "JIS" European Design Std.	N. American Design Std. ^{*2}
A16-*R-01	Suction	F5-06-A-10	F5-06-A-1080	—	F5-06-B-10	F5-06-B-1090	F5-06-C-10	F5-06-C-1090
A22-*R-01	Discharge	F5-06-A-10	F5-06-A-1080	—	F5-06-B-10	F5-06-B-1090	F5-06-C-10	F5-06-C-1090
A37-*R-01	Suction	F5-10-A-10	F5-10-A-1080	—	F5-10-B-10	F5-10-B-1090	F5-10-C-10	F5-10-C-1090
A56-*R-01	Discharge	F5-10-A-10	F5-10-A-1080	—	F5-10-B-10	F5-10-B-1090	F5-10-C-10	F5-10-C-1090
A70-*R01	Suction	F5-12-A-10	F5-12-A-1080	—	F5-12-B-10	F5-12-B-1090	F5-12-C-10	F5-12-C-1090
	Discharge	F5-08-A-10	F5-08-A-1080	—	F5-08-B-10	F5-08-B-1090	F5-08-C-10	F5-08-C-1090
A90-*R01	Suction	F5-16-A-10	F5-16-A-1080	—	F5-16-B-10	F5-16-B-1090	F5-16-C-10	F5-16-C-1090
A145-*R01	Discharge	F5-10-A-10	F5-10-A-1080	—	F5-10-B-10	F5-10-B-1090	F5-10-C-10	F5-10-C-1090

- ★ 1. In case of using socket welding flanges, there is a case where the operating pressure should be set lower than the normal because of strength of the flanges. Therefore, please pay cautious attention to the operating pressure when the socket welding flanges are used.
- ★ 2. As dimensions of the pipe flange mounting surface are conformed to SAE 4 Bolt Split Flange (Standard Pressure Series), pipe flanges conforming to the SAE Standards can be used.
- Details of the pipe flange kits are shown on page 824.



Response Characteristics Change in Accordance with Circuits and Operating Conditions.

Test Circuit and Conditions

Circuit

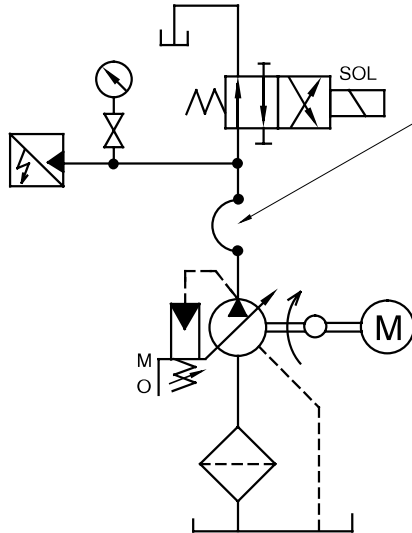

Conditions

- Drive Speed : 1500 r/min
- Hydraulic Fluid : ISO VG32 oil
- Oil Temperature : A10-A56: 50 °C (122 °F) [Viscosity 20 mm²/s (100 SSU)]
A70-A145: 40 °C (104 °F) [Viscosity 32 mm²/s (150 SSU)]

High Pressure Rubber Hose

Model	Ruber Hose Size
A10	1/2" × 800 mm (2.6 ft.)
A16 A22	3/4" × 700 mm (2.3 ft.)
A37 A56	3/4" × 2000 mm (6.6 ft.)
A70	3/4" × 3500 mm (11.5 ft.)
A90 A145	3/4" × 3000 mm (9.8 ft.) + 1-1/4" × 2000 mm (6.6 ft.)

Result of Measurement

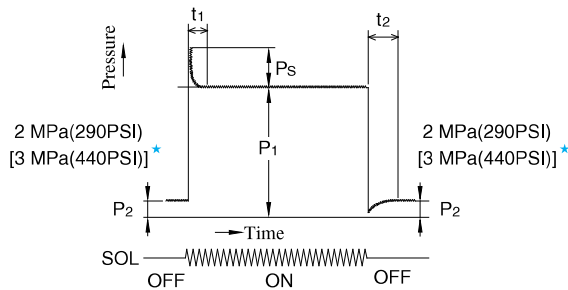

★ Applicable only for "A90/A145"

Model	Full Cut-off Pressure P ₁ MPa (PSI)	Response Time ms		Overshoot Pressure P _s MPa (PSI)
		t ₁	t ₂	
A10	21 (3050)	100	75	2.6 (380)
A16	16 (2320)	38*	59*	3.6 (520)
A22	16 (2320)	30*	72*	5.9 (860)
A37	16 (2320)	40*	78*	7.8 (1130)
A56	16 (2320)	38*	88*	7.6 (1100)
A70	25 (3630)	80	100	7.8 (1130)
A90	25 (3630)	90	110	7.9 (1150)
A145	25 (3630)	100	150	8.8 (1280)

* Response time except A10, A70, A90 and A145 is measured Yoke travel.

Typical Performance Characteristics of Type "A90" at Viscosity 32 mm²/s (150 SSU) [ISO VG32 Oils, 40°C (104°F)]

■ Performance Characteristics Curve

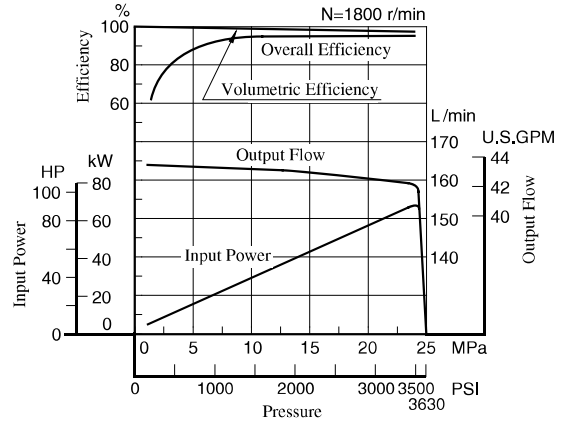
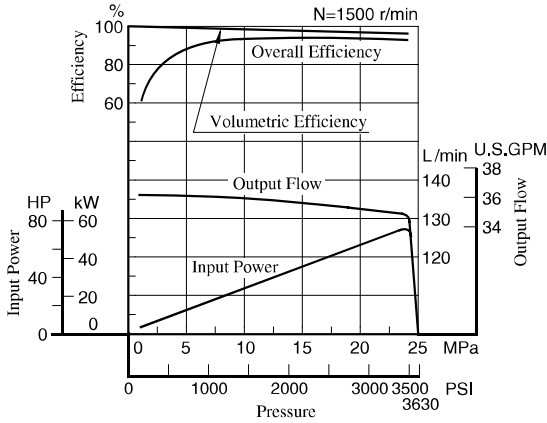

■ Input Power

Example: At a pressure of under 18 MPa (2610 PSI), a flow 110 L/min (29.1 U.S.GPM), and rotation 1500 r/min, the axial input becomes about 34 kW (46 HP) as shown the dotted line in the graph.

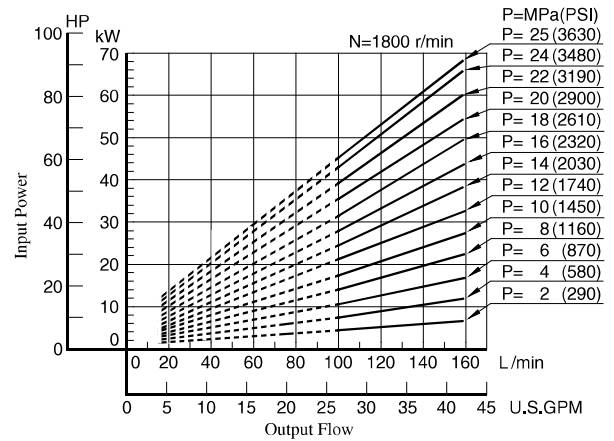
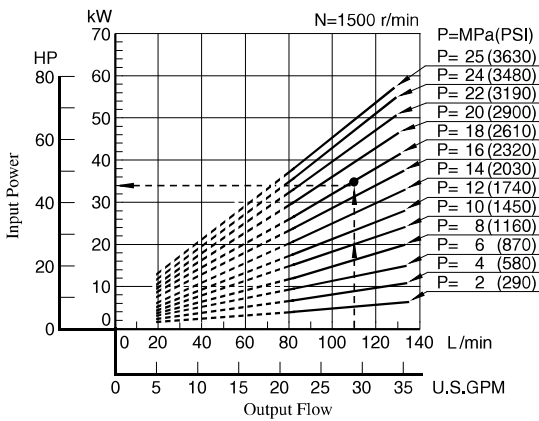

■ Full Cut-off Power

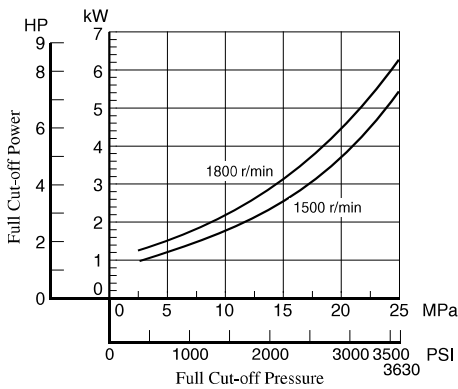

■ Drain

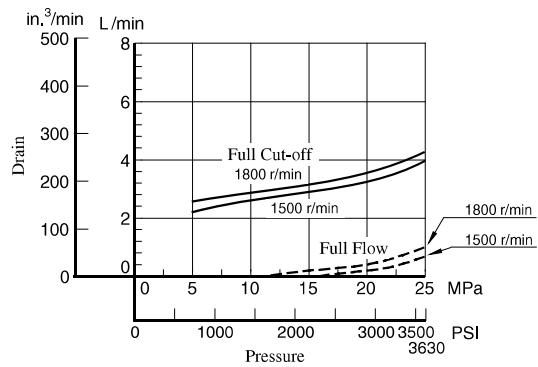

■ Noise Level [One metre (3.3 ft.) horizontally away from pump head cover]

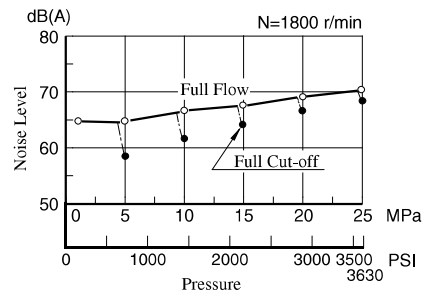
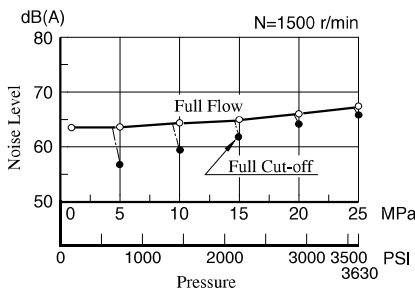

Flange Mtg.: A90-FR01*S-60/6080/60950

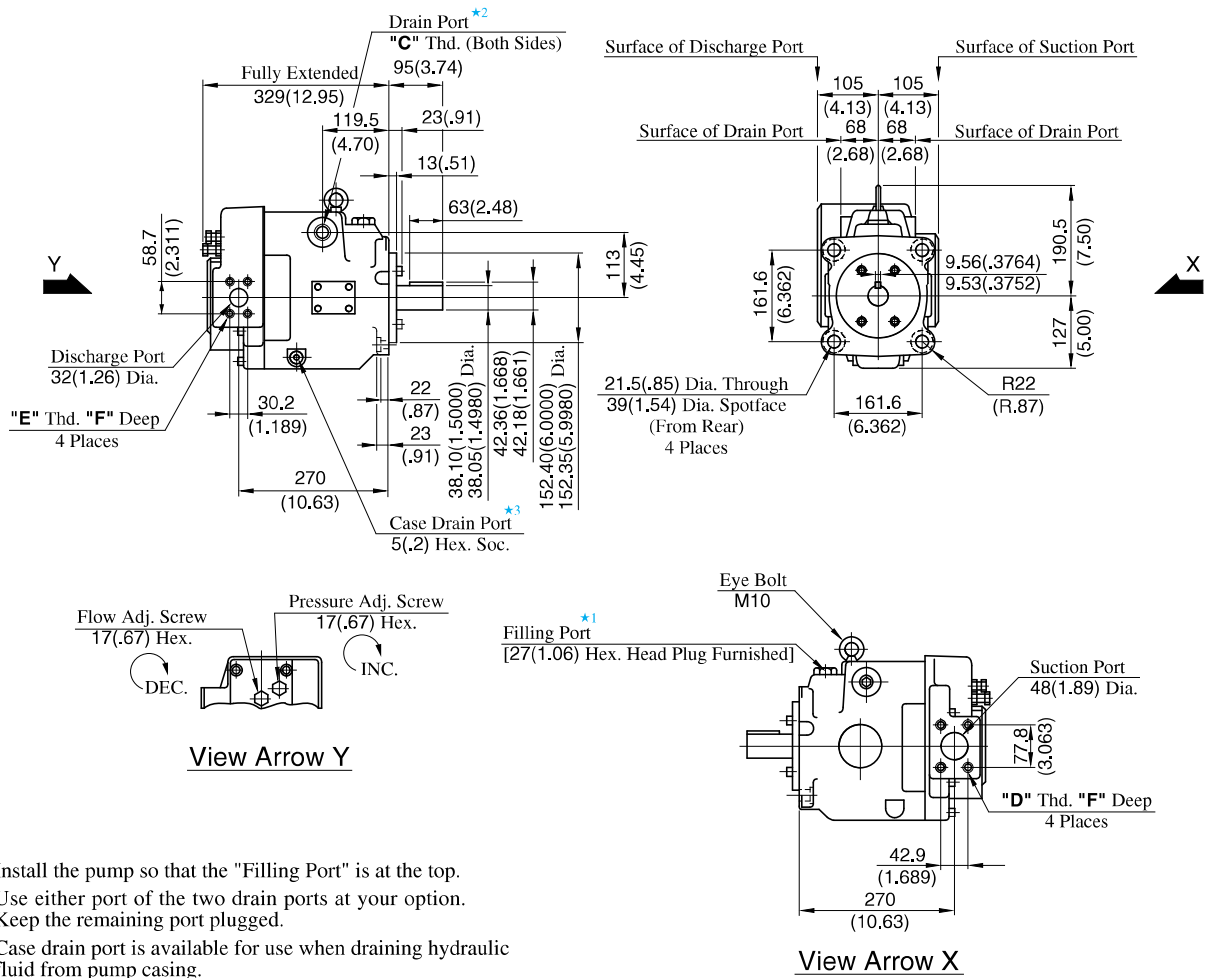

- ★ 1. Install the pump so that the "Filling Port" is at the top.
- ★ 2. Use either port of the two drain ports at your option. Keep the remaining port plugged.
- ★ 3. Case drain port is available for use when draining hydraulic fluid from pump casing.

Model Numbers	"C" Thd.	"D" Thd.	"E" Thd.	F mm (IN.)
A90-FR01*S-60	Rc 3/4	M 12	M 10	19 (.75)
A90-FR01*S-6080	3/4 BSP.F			
A90-FR01*S-60950	SAE #12	1/2-13 UNC	7/16-14 UNC	21 (.83)

DIMENSIONS IN MILLIMETRES (INCHES)

Foot Mtg.: A90-LR01*S-60/6080/60950

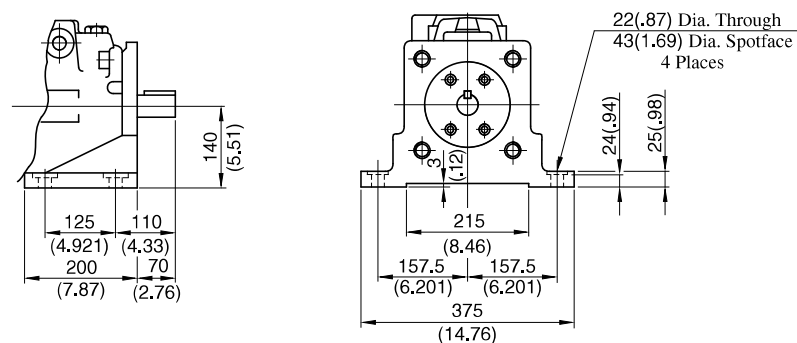

• For other dimensions, refer to "Flange Mtg.".

Spare Parts List

A70/A90-*R01*S-60/6080/60950

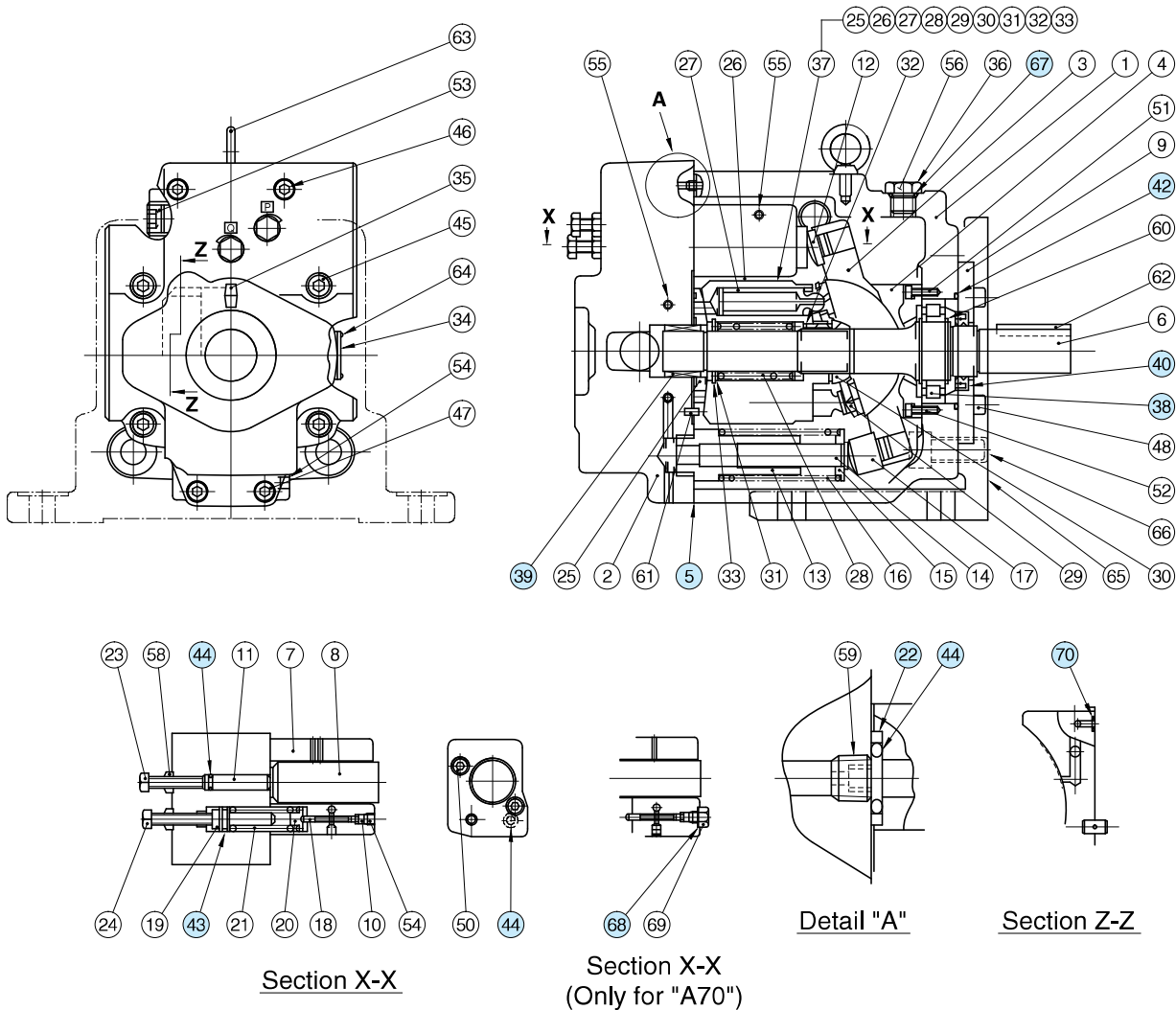

List of Seals and Bearings

Item	Name of Parts	Part Numbers		Qty.
		A70-*R01*S	A90-*R01*S	
5*	Gasket	1314E-PK211972-5	1310E-PK211973-3	1
22	Back Up Ring	1310E-PK412440-0	1310E-PK412440-0	1
38	Bearing	NUP 208EX50	NUP 210E	1
39	Needle Bearing	HMK 3030V2	HMK 3530BV2	1
40*	Oil Seal	TCN 355511	TCN 456812	1
42*	O-Ring	SO-FA-G85	SO-FA-G95	1
43*	O-Ring	SO-NA-P18	SO-NA-P18	1
44*	O-Ring	SO-NB-P9	SO-NB-P9	3
67*	O-Ring	SO-NB-P14	SO-NB-P18	1
68*	Seal Washer	W10	—	1
70*	O-Ring	SO-NB-P15	SO-NB-P5	1

List of Seal Kits

Pump Model Numbers	Seal Kit Numbers
A70-*R01*S-60*	KS-A70-01-60
A90-*R01*S-60*	KS-A90-01-60

★ When ordering the seals, please specify the seal kit number from the table left.



"A" Series Variable Displacement Piston Pumps – Single Pump, Solenoid Two Pressure Control Type

Graphic Symbol

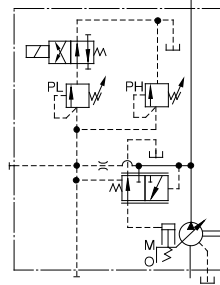

Performance Characteristics

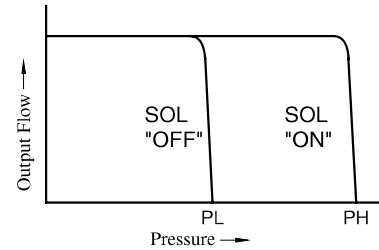

Specifications

Model Numbers	Geometric Displacement cm ³ /rev (cu. in. /rev)	Minimum Adj. Flow cm ³ /rev (cu. in. /rev)	Operating Pressure MPa (PSI)		Minimum Adj. Pres. MPa (PSI)	Shaft Speed Range r/min		Approx. Mass kg (lbs.)	
			Rated ^{*2}	Intermittent ^{*1}		Max.	Min.	Flange Mtg.	Foot Mtg.
A16-*-R-02-*-K*-32*	15.8 (.964)	4 (.244)	16 (2320)	21 (3050)	1.2 (170)	1800	600	24.5 (54.0)	26.7 (58.9)
A22-*-R-02-*-K*-32*	22.2 (1.355)	6 (.366)	16 (2320)	16 (2320)	1.2 (170)	1800	600	24.5 (54.0)	26.7 (58.9)
A37-*-R-02-*-K*-32*	36.9 (2.25)	10 (.61)	16 (2320)	21 (3050)	1.2 (170)	1800	600	36 (79.4)	40.3 (88.9)
A56-*-R-02-*-K*-32*	56.2 (3.43)	12 (.73)	16 (2320)	21 (3050)	1.2 (170)	1800	600	43 (94.8)	47.3 (104)
A70-*-R02S*-60*	70.0 (4.27)	30 (1.83)	25 (3630)	25 (3630)	2 (290)	1800	600	63.5 (140)	75.5 (166)
A90-*-R02S*-60*	91.0 (5.55)	56 (3.42)	25 (3630)	25 (3630)	2 (290)	1800	600	80.5 (178)	101 (223)
A145-*-R02S*-60*	145 (8.85)	83 (5.06)	25 (3630)	25 (3630)	2 (290)	1800	600	97.5 (215)	122.5 (270)

★1. Whenever setting pressure, make sure the full cut-off pressure never exceeds the maximum intermittent pressure. ★2. When operating the pump exceeding the rated pressure, operating conditions are restricted. Refer to [page 33](#) for the details.

Solenoid Ratings

Solenoid operated directional valves used on these pumps are YUKEN DSG-01 series (standard type). For detail specifications of solenoid operated directional valves, refer to [page 345](#).