

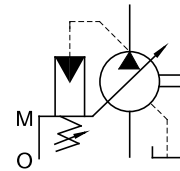

"AR" Series Variable Displacement Piston Pumps – Single Pump, Pressure Compensator Type



Graphic Symbol



Specifications

Model Numbers	Geometric Displacement cm ³ /rev (cu.in./rev)	Operating Pressure MPa (PSI)		Shaft Speed Range r/min.		Approx. Mass kg (lbs.)
		Rated	Intermittent*	Max.	Min.	
AR16-FR01*-20/2080/20950	15.8 (.964)	16 (2320)		1800	600	9.8 (21.6)
AR22-FR01*-20/2080/20950	22.2 (1.355)			1800	600	

* When setting the pressure, make sure the full cut-off pressure never exceeds the maximum intermittent pressure.

Model Number Designation

AR16	-F	R	01	B	S	-20	*
Series Number	Mounting	Direction of Rotation	Control Type	Pres. Adj. Range MPa (PSI)	Port Position	Design Number	Design Std.
AR16 (15.8 cm ³ /rev)	F: Flange Mtg.	(Viewed from Shaft End) R: ★1 Clockwise (Normal)	01: Pressure Compensator Type	B: 1.2 - 7 {170 - 1020} C: 2.0 - 16 {290 - 2320}	None: Axial Port S: Side Port	20	Refer to ★2
AR22 (22.2 cm ³ /rev)						20	

★1. Available to supply pump with anti-clockwise rotation. Consult Yuken for details.

★2. Design Standards:
None..... Japanese Standard "JIS"
80..... European Design Standard
950..... N. American Design Standard

Pipe Flange Kits

Pipe flange kits are available.
When ordering, specify the kit number from the table below.

Pump Model Numbers	Name of Port	Pipe Flange Kit Numbers				
		Threaded Connection			Socket Welding	
		Japanese Standard "JIS"	European Design Standard	N. American Design Standard	Japanese Standard "JIS" European Design Standard	N. American Design Standard
AR16-FR01 AR22-FR01	Suction	F5-06-A-1021	F5-06-A-10801	F5-06-A-10950	F5-06-B-1021	F5-06-B-10901
	Discharge *	_____	_____	_____	_____	_____

★ Discharge port is available only for the threaded connections.

• Detail of the pipe flange kits are shown on [page 24](#).

Mounting Bracket Kits

Mounting bracket available on separate order.
Refer to [page 24](#) for dimensions of the Mtg. bracket.

Pump Model Numbers	Mtg. Bracket Kit Numbers	Approx. Mass kg (lbs.)
AR16/AR22-FR01	LP-1A-10	2.2 (4.9)

Note: The mounting bracket kit consists of a mounting bracket, two hex. bolts and two plain washers.

Typical Pump Characteristics of Type "AR16" at Viscosity 20 mm²/s (100 SSU) [ISO VG32 Oils, 50°C (122°F)]

■ Performance Characteristic Curve

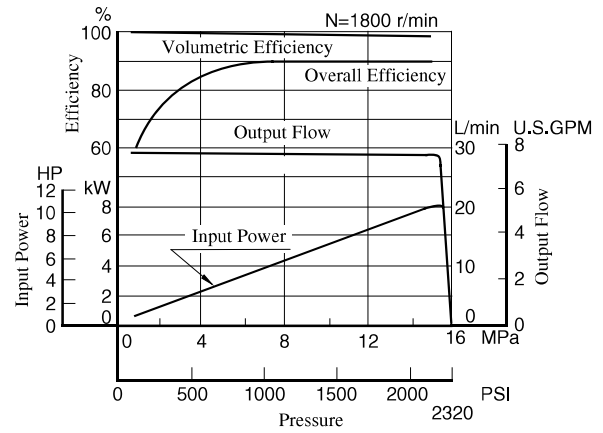
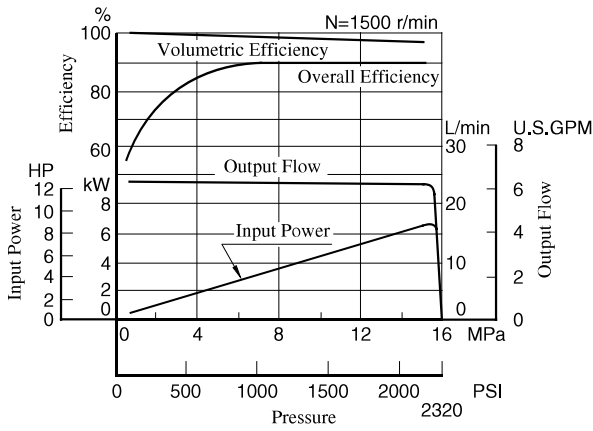

■ Input Power

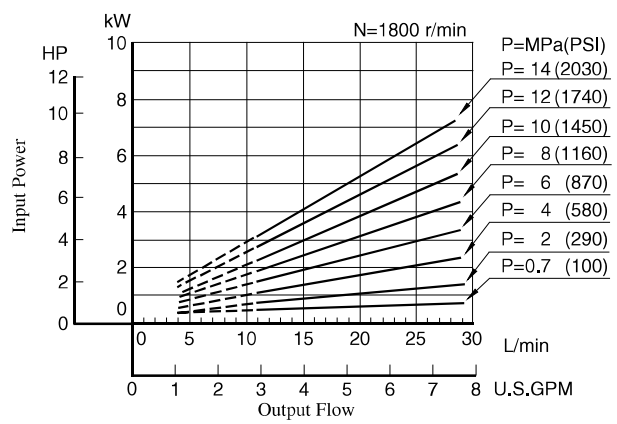
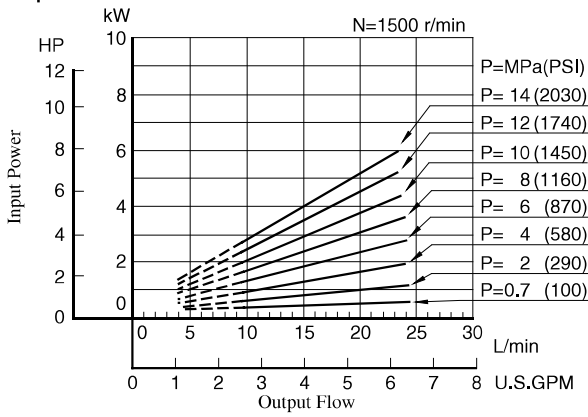

■ Full Cut-off Power

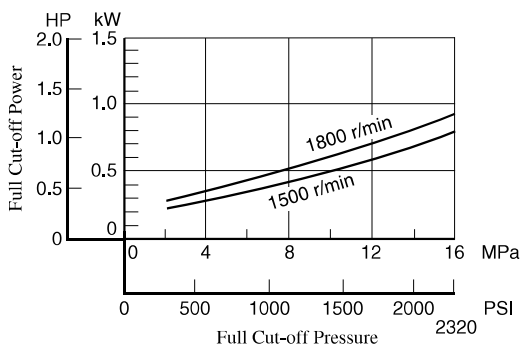

■ Drain

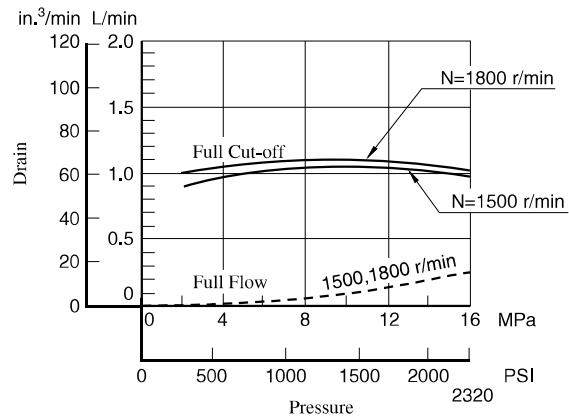

■ Noise Level [One metre (3.3 ft.) horizontally away from pump head cover]

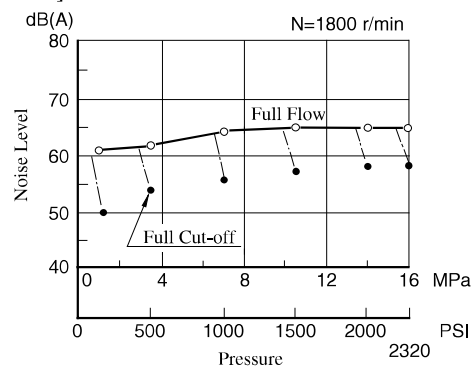
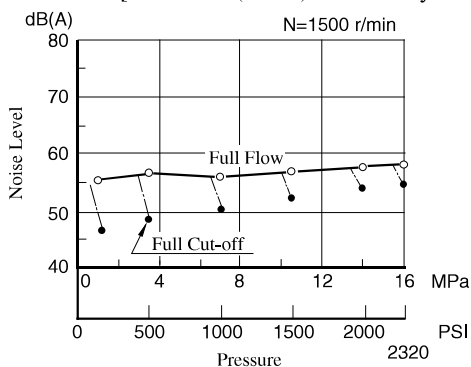

Response Characteristics Change in Accordance with Circuits and Operating Conditions.

■ Test Circuit and Conditions

● **Circuit**

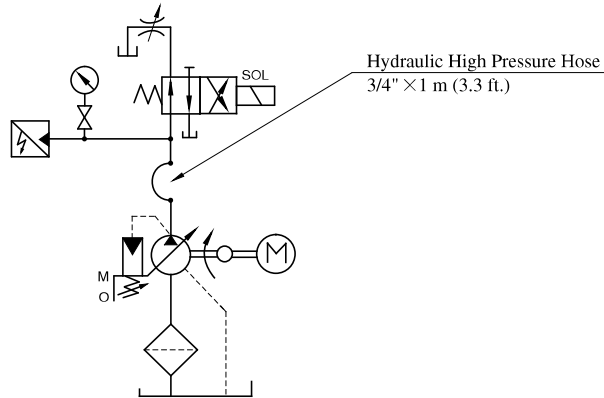

● **Conditions**

- Drive Speed : 1500 r/min
- Hydraulic Fluid : ISO VG32 oil
- Oil Temperature : 50 °C (122 °F)
- Viscosity : 20 mm²/s (100 SSU)

■ Result of Measurement

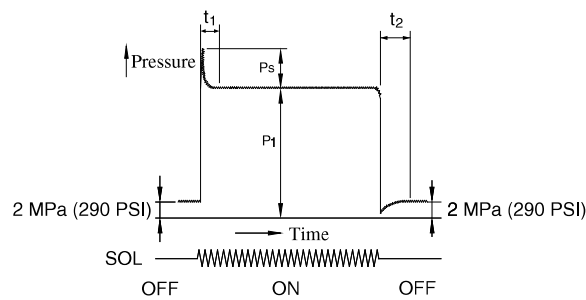

Model	Full Cut-off Pressure P ₁ MPa (PSI)	Response Time ms		Overshoot Pressure P _s MPa (PSI)
		t ₁	t ₂	
AR16	16 (2320)	60	65	5.6 (810)
AR22		70	70	7.3 (1060)

AR16-FR01*-20/2080/20950
AR22-FR01*-20/2080/20950

Axial Port Type

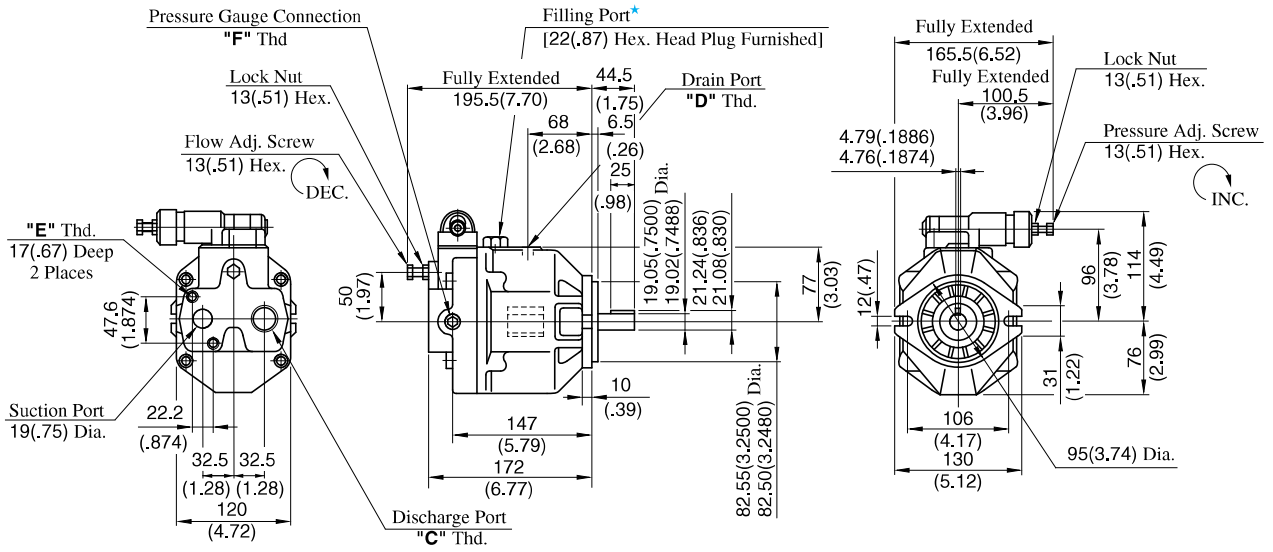

* Install the pump so that the "Filling port" is at the top.

Model Numbers	"C" Thd.	"D" Thd.	"E" Thd.	"F" Thd.
AR16/AR22-FR01*-20	Rc 3/4	Rc 3/8	M10	Rc 1/4
AR16/AR22-FR01*-2080	3/4 BSP.F	3/8 BSP.F		1/4 BSP.Tr
AR16/AR22-FR01*-20950	SAE #12	SAE #8	3/8-16 UNC	SAE #4

DIMENSIONS IN MILLIMETRES (INCHES)

AR16-FR01*S-20/2080/20950
AR22-FR01*S-20/2080/20950

Side Port Type

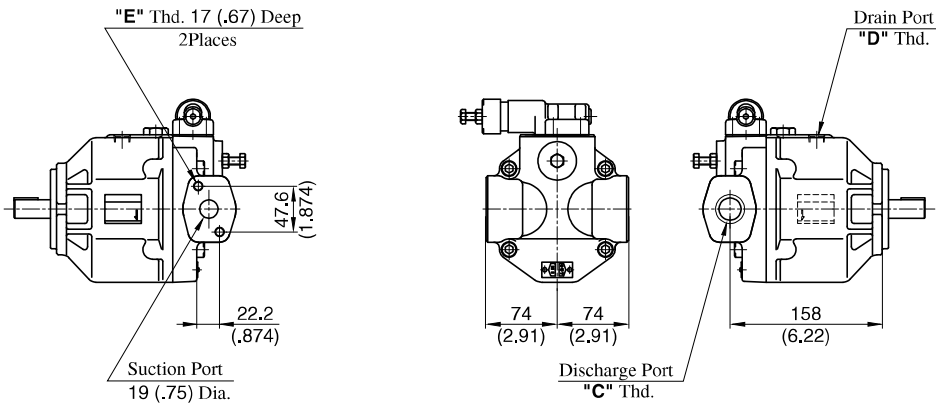

Model Numbers	"C" Thd.	"D" Thd.	"E" Thd.
AR16/AR22-FR01*S-20	Rc 3/4	Rc 3/8	M10
AR16/AR22-FR01*S-2080	3/4 BSP.F	3/8 BSP.F	
AR16/AR22-FR01*S-20950	SAE #12	SAE #8	3/8-16 UNC

• For other dimensions, refer to "Axial Port Type".

Spare Parts List

AR16-FR01*-20/2080/20950
AR22-FR01*-20/2080/20950

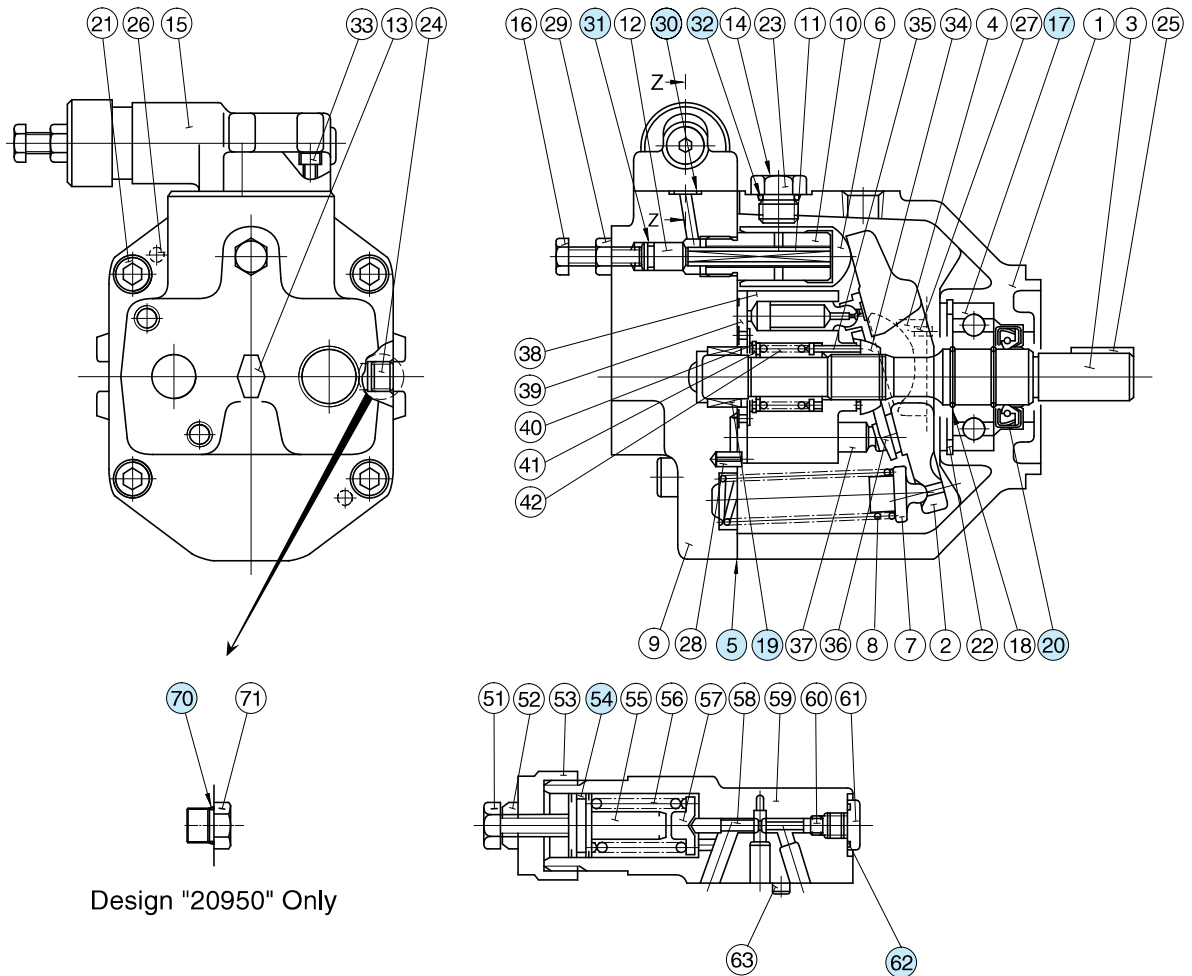

Section Z-Z

List of Seals & Bearings

Item	Name of Parts	Part Numbers		Qty.
		AR16-FR01	AR22-FR01	
5*	Gasket	1302-PK312891-5		1
17	Bearing	6305		1
19	Bearing	HMK 1715 V2	Z30-1303-PK410300-8	1
20*	Oil Seal	TCN 254511		1
30*	O-Ring	SO-NB-P9		3
31*	O-Ring	SO-NA-P8		1
32*	O-Ring	SO-NB-P14		1
54*	O-Ring	SO-NA-A018		1
62*	O-Ring	SO-NB-P10		1
70	O-Ring	SO-NB-A905		1

*When ordering seals, please specify the seal kit number from the table below.

List of Seal Kits

Pump Model Numbers	Seal Kit Number
AR16-FR01*-20/2080/20950	KS-AR16-01-20
AR22-FR01*-20/2080/20950	

Interchangeability in Installation between "A" Series and "AR" Series

Specifications

Model		A16-*-R-01-*-K-32*	AR16-FR01*-20*	A22-*-R-01-*-K-32*	AR22-FR01*-20*
Description		A16-*-R-01-*-K-32*	AR16-FR01*-20*	A22-*-R-01-*-K-32*	AR22-FR01*-20*
Geometric Displacement		15.8 cm ³ /rev (.964 cu.in./rev)		22.2 cm ³ /rev (1.355 cu.in./rev)	
Operating Pres.	Rated	16 MPa (2320 PSI)		16 MPa (2320 PSI)	
	Intermittent	21 MPa (3050 PSI)	16 MPa (2320 PSI)	16 MPa (2320 PSI)	
Shaft Speed Range		600 -1800 r/min		600 -1800 r/min	
Approx. Mass (Flange Mtg.)		16.5 kg (36.4 lbs.)	9.8 kg (21.6 lbs.)	16.5 kg (36.4 lbs.)	9.8 kg (21.6 lbs.)

Interchangeability in Installation

Model Numbers		Interchangeability in Installation			
"A" Series	"AR" Series	Mtg. Flange & Shaft End	Piping		
			Suction Port	Discharge Port	Drain Port
A16-*-R-01-*-K-32*	AR16-FR01*-20*	Yes	Yes	No	No
A22-*-R-01-*-K-32*	AR22-FR01*-20*				

● Comparison of dimensions between "A" series and "AR" series are shown below.

A16/A22-F-R-01-*-K

Note: Dimensions with star mark ★ are identical to each other.

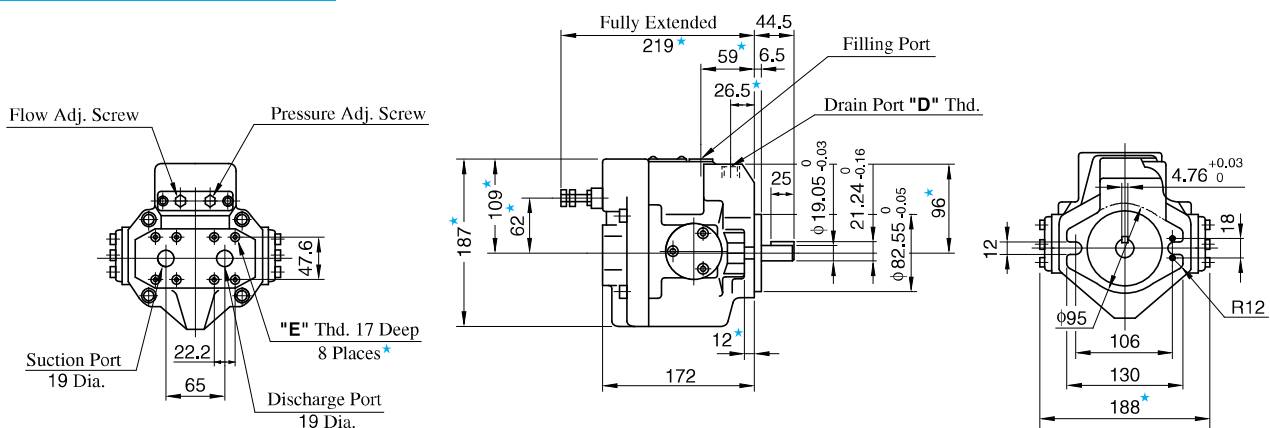

Model Numbers	"C" Thd.	"D" Thd.	"E" Thd.	"F" Thd.
A16/A22-F-R-01-*-K-32	—	Rc 3/8	M10	—
A16/A22-F-R-01-*-K-3280	—	3/8 BSP.F		—
A16/A22-F-R-01-*-K-32950	—	SAE #8		3/8-16 UNC
AR16/22-FR01*-20	Rc 3/4	Rc 3/8	M10	Rc 1/4
AR16/22-FR01*-2080	3/4 BSP.F	3/8 BSP.F		1/4 BSP.Tr
AR16/22-FR01*-20950	SAE #12	SAE #8	3/8-16 UNC	SAE #4

AR16/AR22-FR01

