

## Right Angle Check Valves

These valves allow free flow in one direction and prevent flow in the reverse direction. Cracking pressure specified is the pressure required to open the valve and allow free flow.

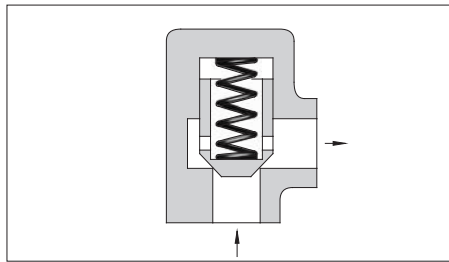

Graphic Symbol

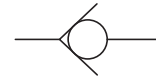

### Specifications

Type of Connection	Model Numbers	Rated Flow* L/min (U.S.GPM)	Max. Operating Pres. MPa (PSI)	Cracking Pres. MPa (PSI)	Approx. Mass kg (lbs.)
Threaded Connection	CRT-03-* -50/5080/5090	40 (10.6)	25 (3630)	0.04 (6)	0.9 (2.0)
	CRT-06-* -50/5080/5090	125 (33)		0.35 (50)	1.7 (3.7)
	CRT-10-* -50/5080/5090	250 (66)		0.5 (70)	5.6 (12.3)
Sub-plate Mounting	CRG-03-* -50/5090	40 (10.6)	25 (3630)	0.04 (6)	1.7 (3.7)
	CRG-06-* -50/5090	125 (33)		0.35 (50)	2.9 (6.4)
	CRG-10-* -50/5090	250 (66)		0.5 (70)	5.5 (12.1)

\* Rated flow is the approximate flow rate, when there is a free flow pressure drop of maximum 0.3 MPa (44 PSI), the fluid has a specific gravity of 0.85 and a kinematic viscosity of 20 mm<sup>2</sup>/s (98 SSU), and the cracking pressure is 0.04 MPa (6 PSI).

### Model Number Designation

F-	CR	T	-03	-04	-50	*
Special Seals	Series Number	Type of Connection	Valve Size	Cracking Pressure MPa (PSI)	Design Number	Design Standards
<b>F:</b> Special seals for phosphate ester type fluids (Omit if not required)	<b>CR:</b> Right Angle Check Valve	<b>T:</b> Threaded Connection	<b>03</b>	<b>04:</b> 0.04 (6)	<b>50</b>	<b>None:</b> Japanese Std. "JIS" <b>80:</b> European Design Std. <b>90:</b> N. American Design Std.
			<b>06</b>	<b>35:</b> 0.35 (50)	<b>50</b>	
			<b>10</b>	<b>50:</b> 0.5 (70)	<b>50</b>	
		<b>G:</b> Sub-plate Mounting	<b>03</b>	<b>04:</b> 0.04 (6)	<b>50</b>	<b>None:</b> Japanese Std. "JIS" & European Design Std. <b>90:</b> N. American Design Std.
			<b>06</b>	<b>35:</b> 0.35 (50)	<b>50</b>	
			<b>10</b>	<b>50:</b> 0.5 (70)	<b>50</b>	

### Sub-plate

Valve Model Numbers	Japanese Standard "JIS"		European Design Standard		N.American Design Standard		Approx. Mass kg (lbs.)
	Sub-plate Model Numbers	Thread Size	Sub-plate Model Numbers	Thread Size	Sub-plate Model Numbers	Thread Size	
CRG-03	CRGM-03-50	Rc 3/8	CRGM-03-5080	3/8 BSP.F	CRGM-03-5090	3/8 NPT	1.6 (3.5)
	CRGM-03X-50	Rc 1/2	CRGM-03X-5080	1/2 BSP.F	CRGM-03X-5090	1/2 NPT	1.6 (3.5)
CRG-06	CRGM-06-50	Rc 3/4	CRGM-06-5080	3/4 BSP.F	CRGM-06-5090	3/4 NPT	2.4 (5.3)
	CRGM-06X-50	Rc 1	CRGM-06X-5080	1 BSP.F	CRGM-06X-5090	1 NPT	3.0 (6.6)
CRG-10	CRGM-10-50	Rc 1-1/4	CRGM-10-5080	1-1/4 BSP.F	CRGM-10-5090	1-1/4 NPT	4.8 (10.6)
	CRGM-10X-50	Rc 1-1/2	CRGM-10X-5080	1-1/2 BSP.F	CRGM-10X-5090	1-1/2 NPT	5.7 (12.6)

● Sub-plates are available. Specify the sub-plate model number from the table above. When sub-plates are not used, the mounting surface should have a good machined finish.

Yuken can offer flanged connection valves described below. For details, contact us.

Model No.	Rated Flow L/min (U.S.GPM)	Max. Operating Pressure MPa (PSI)
CRF-10-* -50*	300 (79.3)	25 (3630)
CRF-16-* -50*	600 (159)	
CRF-24-* -50*	1300 (343)	

### Mounting Bolts

Socket head cap screws in the table below are included.

Valve Model Numbers	Socket Head Cap Screw		Qty.
	Japanese Standard "JIS" European Design Standard	N.American Design Standard	
CRG-03	M10 × 45 Lg.	3/8-16 UNC × 1-3/4 Lg.	4
CRG-06	M10 × 50 Lg.	3/8-16 UNC × 2 Lg.	4
CRG-10	M10 × 55 Lg.	3/8-16 UNC × 2-1/4 Lg.	6

CRT-03-\*50/5080/5090  
 CRT-06-\*50/5080/5090  
 CRT-10-\*50/5080/5090

## DIMENSIONS IN MILLIMETRES (INCHES)

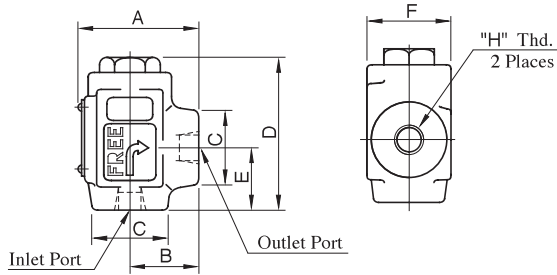

Model Numbers	Dimensions mm (Inches)						"H" Thd.
	A	B	C	D	E	F	
CRT-03-*50	62	36	38	80.5	33	44	Rc 3/8
CRT-03-*5080	(2.44)	(1.42)	(1.50) Dia	(3.17)	(1.30)	(1.73)	3/8 BSP.F
CRT-03-*5090							3/8 NPT
CRT-06-*50	74	45	54	104.5	49	54	Rc 3/4
CRT-06-*5080	(2.91)	(1.77)	(2.13) Dia	(4.11)	(1.93)	(2.13)	3/4 BSP.F
CRT-06-*5090							3/4 NPT
CRT-10-*50	107	65	80	130	65	80	Rc 1-1/4
CRT-10-*5080	(4.21)	(2.56)	(3.15) SQ.	(5.12)	(2.56)	(3.15)	1-1/4 BSP.F
CRT-10-*5090							1-1/4 NPT

CRG-03-\*50/5090  
 CRG-06-\*50/5090

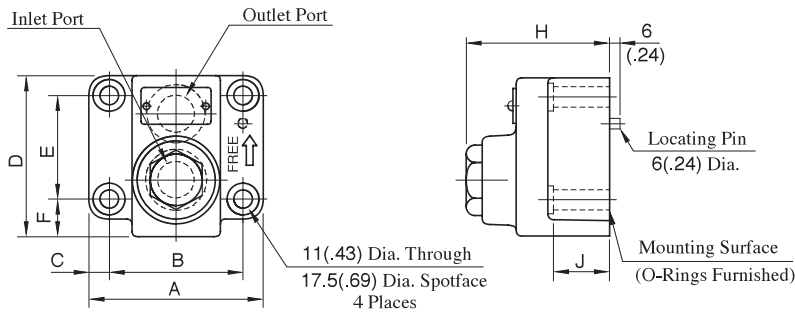

Model Numbers	Dimensions mm (Inches)								Mounting Surface
	A	B	C	D	E	F	H	J	
CRG-03	90	66.7	11.7	72	42.9	17.5	72.5	30	ISO 5781-AG-06-2-A
	(3.54)	(2.63)	(.46)	(2.83)	(1.69)	(.69)	(2.85)	(1.18)	
CRG-06	102	79.4	11.3	93	60.3	21.4	84.5	35	ISO 5781-AH-08-2-A
	(4.02)	(3.13)	(.44)	(3.66)	(2.37)	(.84)	(3.33)	(1.38)	

CRG-10-\*50/5090

Mounting surface: ISO 5781-AJ-10-2-A

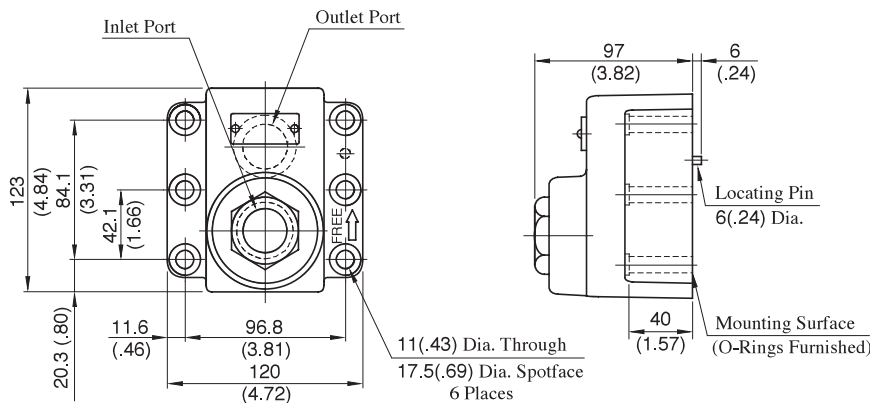

**Sub-plate**

CRGM-03-50/5080/5090  
CRGM-03X-50/5080/5090

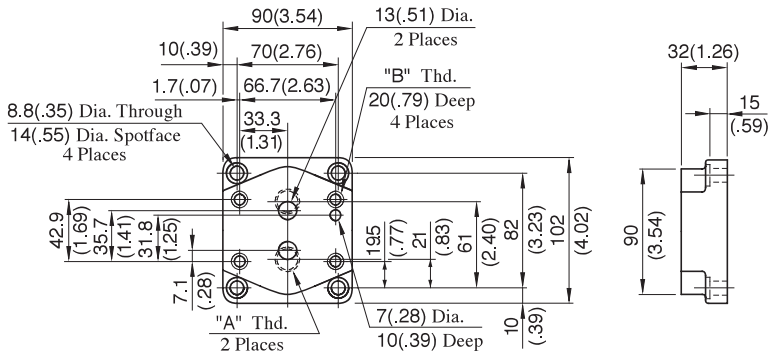

Sub-plate Model Numbers	Thread Size	
	"A" Thd.	"B" Thd.
CRGM-03-50	Rc 3/8	M10
CRGM-03-5080	3/8 BSP.F	
CRGM-03-5090	3/8 NPT	3/8-16 UNC
CRGM-03X-50	Rc 1/2	M10
CRGM-03X-5080	1/2 BSP.F	
CRGM-03X-5090	1/2 NPT	3/8-16 UNC

**DIMENSIONS IN MILLIMETRES (INCHES)**

CRGM-06-50/5080/5090  
CRGM-06X-50/5080/5090

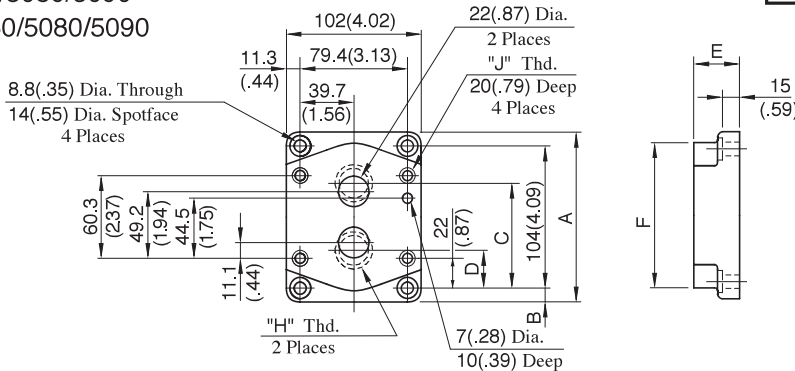

Sub-plate Model Numbers	Dimensions mm (Inches)						Thread Size	
	A	B	C	D	E	F	"H" Thd.	"J" Thd.
CRGM-06-50							Rc 3/4	M10
CRGM-06-5080	124 (4.88)	10 (.39)	77 (3.03)	27 (1.06)	36 (1.42)	110 (4.33)	3/4 BSP.F	
CRGM-06-5090							3/4 NPT	3/8-16 UNC
CRGM-06X-50			82.3 (3.24)	22 (.87)			Rc 1	M10
CRGM-06X-5080	136 (5.35)	16 (.63)	80 (3.15)	24 (.94)	45 (1.77)	130 (5.12)	1 BSP.F	
CRGM-06X-5090			82.3 (3.24)	22 (.87)			1 NPT	3/8-16 UNC

CRGM-10-50/5080/5090  
CRGM-10X-50/5080/5090

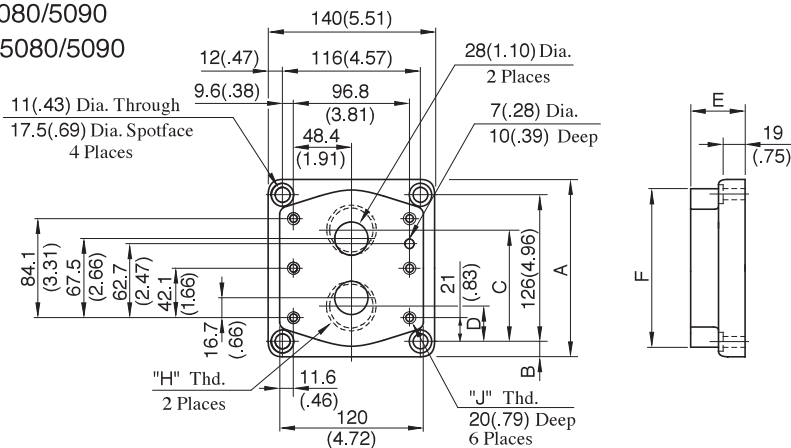

Sub-plate Model Numbers	Dimensions mm (Inches)						Thread Size	
	A	B	C	D	E	F	"H" Thd.	"J" Thd.
CRGM-10-50							Rc 1-1/4	M10
CRGM-10-5080	150 (5.91)	12 (.47)	96 (3.78)	30 (1.18)	45 (1.77)	135 (5.31)	1-1/4 BSP.F	
CRGM-10-5090							1-1/4 NPT	3/8-16 UNC
CRGM-10X-50							Rc 1-1/2	M10
CRGM-10X-5080	177 (6.97)	25.5 (1.00)	104 (4.09)	22 (.87)	50 (1.97)	167 (6.57)	1-1/2 BSP.F	
CRGM-10X-5090							1-1/2 NPT	3/8-16 UNC

## Pressure Drop

Hydraulic Fluid: Viscosity 30mm<sup>2</sup>/s (141 SSU), Specific Gravity 0.850

### ● CRT-03

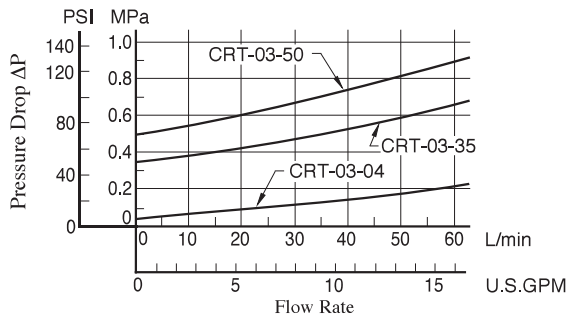

### ● CRG-03

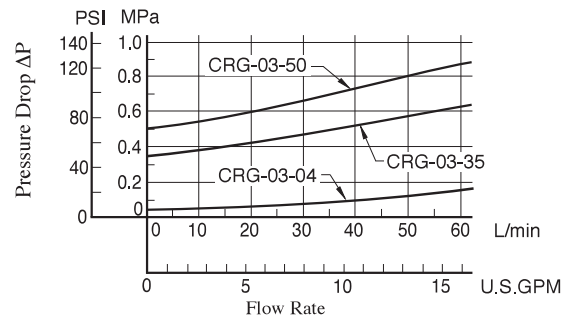

### ● CRT-06

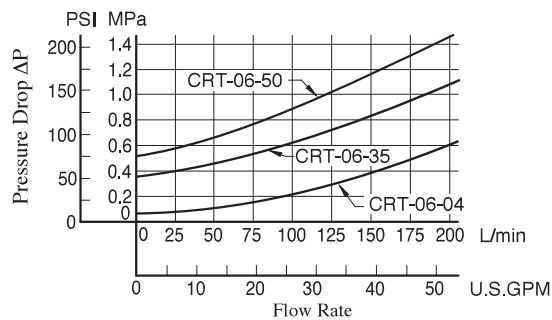

### ● CRG-06

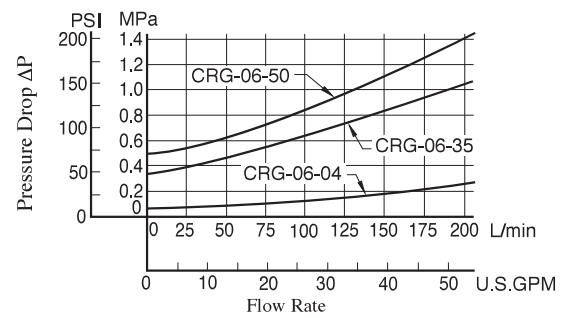

### ● CRT-10

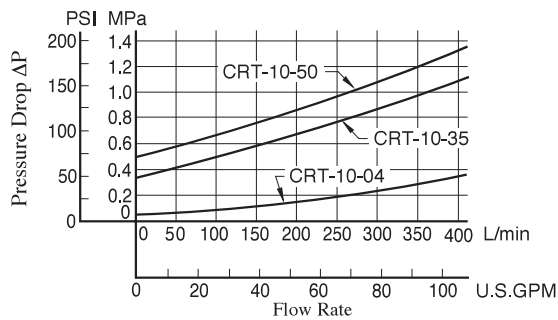

### ● CRG-10

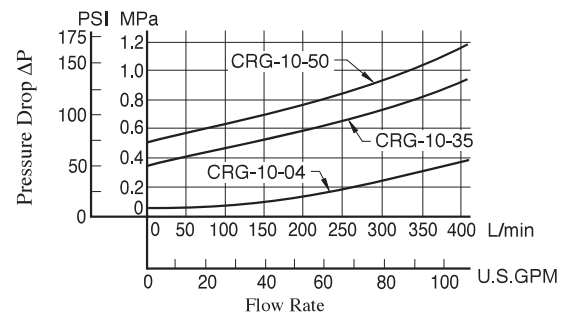

## List of Seals

CRT-03-50/5080/5090  
 CRT-06-50/5080/5090  
 CRT-10-50/5080/5090

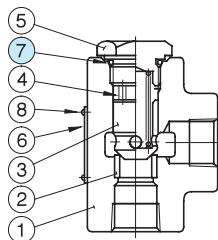

CRG-03-50/5090  
 CRG-06-50/5090  
 CRG-10-50/5090

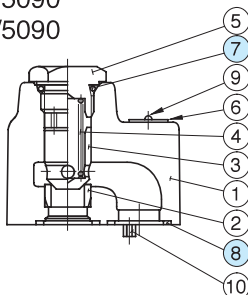

### ● List of Seals & Seal Kits

Item	Name of Parts	Part Numbers			Qty.
		CRT-03	CRT-06	CRT-10	
7	O-Ring	SO-NB-P21	SO-NB-P24	SO-NB-P32	1
★	Seal Kit	KS-CRT-03-50	KS-CRT-06-50	KS-CRT-10-50	—

★ When ordering the O-Rings, please specify the seal kit number from the table above.

### ● List of Seals & Seal Kits

Item	Name of Parts	Part Numbers			Qty.
		CRG-03	CRG-06	CRG-10	
7	O-Ring	SO-NB-P21	SO-NB-P24	SO-NB-P32	1
8	O-Ring	SO-NB-P18	SO-NB-P28	SO-NB-P32	2
★	Seal Kit	KS-CRG-03-50	KS-CRG-06-50	KS-CRG-10-50	—

★ When ordering the O-Rings, please specify the seal kit number from the table above.